

ED. II

Contemporary Ceramic Surfaces
& Signature Surfaces

LEWANG
THROUGH
SILENCE

LIVING THROUGH SILENCE



WE MOVE THROUGH A WORLD
FULL OF VOICES





[MANIFESTO]



Everything seems to rush forward, trying to be seen, heard, remembered. Yet there is a quieter, more genuine place where things simply are. In that space, silence is not emptiness. It is where we breathe, where light settles gently, where touch becomes an honest language. Here, material reveals itself as it truly is: sincere, close, human.

To create, for us, is to listen.
To observe what already exists and accompany it with respect.
To let every texture speak, allowing each form to find its own calm.

Silence teaches us to look differently — to pause, to recognise beauty in what is essential. It reminds us that not every space needs to be filled. Sometimes it is enough to simply be, to let things breathe. We live through silence because in it we find meaning, balance, truth. Because when everything becomes still, beauty grows clear, emotion becomes simple, and we become whole. For us, this silence is a way of inhabiting the world: creating with intention, seeing with tenderness, and welcoming matter with gratitude.

Vivimos rodeados de estímulos. Todo parece moverse demasiado rápido, buscando ser visto, escuchado, recordado. Pero hay un lugar más sereno, más real, donde las cosas simplemente son. En ese lugar, el silencio no es vacío. Es el espacio donde respiramos, donde la luz se posa sin prisa, donde el tacto se convierte en un lenguaje sincero. Ahí, la materia se revela tal como es: honesta, cercana, humana.

Crear, para nosotros, es escuchar.
Es observar lo que ya existe y acompañarlo con respeto.
Es dejar que cada textura hable,
que cada forma encuentre su propia calma.

El silencio nos enseña a mirar distinto, a detenemos, a reconocer la belleza en lo esencial. Nos recuerda que no hace falta llenar cada espacio, que a veces basta con estar, con permitir que las cosas respiren.
Vivimos a través del silencio porque en él encontramos sentido, equilibrio, verdad. Porque cuando todo se detiene, la belleza se vuelve clara, la emoción se vuelve simple, y nosotros, completos. Para nosotros, ese silencio es una forma de estar en el mundo: de crear con pausa, de mirar con ternura, de habitar la materia con gratitud.



LIVING THROUGH SILENCE



Our showrooms

WELCOME HOME

EN.

A showroom, for us, has never been just a place to display ceramics. It is a space that invites you in, that welcomes with calm, and reflects our way of understanding design: warm, human, serene. It is not merely a door that opens, but an environment that holds you gently. A refuge where light settles softly, where textures speak in a quiet voice, and ideas find the silence they need to take shape.

In Vila-real, we wrote the first line of our story. From that beginning, our path extended to Barcelona and later to Madrid, growing with the same natural rhythm with which a thoughtful idea evolves. That expansion has never changed what matters most: our willingness to accompany, to listen, to be of use, to walk beside those who place their trust in our way of seeing design.

These spaces are more than destinations. They are a statement of how we create—a shared experience, a gentle conversation, a place where one can truly feel part of something. Here, every project begins with a welcome. And every encounter reminds us that design—like home—is something built with time, with intention, and, above all, together.

ES.

Un showroom, para nosotros, nunca ha sido solo un espacio donde exhibir cerámica. Es un lugar que invita a entrar, que recibe con calma y que refleja nuestra forma de entender el diseño: cercana, humana, serena. No es simplemente una puerta que se abre, sino un entorno que acoge. Un refugio donde la luz se posa con suavidad, donde las texturas hablan en voz baja y las ideas encuentran el silencio necesario para tomar forma.

En Vila-real escribimos la primera línea de nuestra historia. Desde ese punto inicial, nuestro recorrido se ha expandido hacia Barcelona y, más tarde, hacia Madrid, ampliando nuestra presencia con la misma naturalidad con la que evoluciona una idea bien pensada. Esa expansión nunca ha cambiado lo esencial: nuestra voluntad de acompañar, de escuchar, de ser útiles, de caminar al lado de quienes confían en nuestra forma de entender el diseño.

Estos espacios son más que destinos. Son una declaración de nuestra manera de crear. Una experiencia compartida, una conversación serena, un lugar donde sentirse parte. Aquí, cada proyecto comienza con una bienvenida. Y cada encuentro nos recuerda que el diseño —como el hogar— se construye con tiempo, con intención y, sobre todo, juntos.



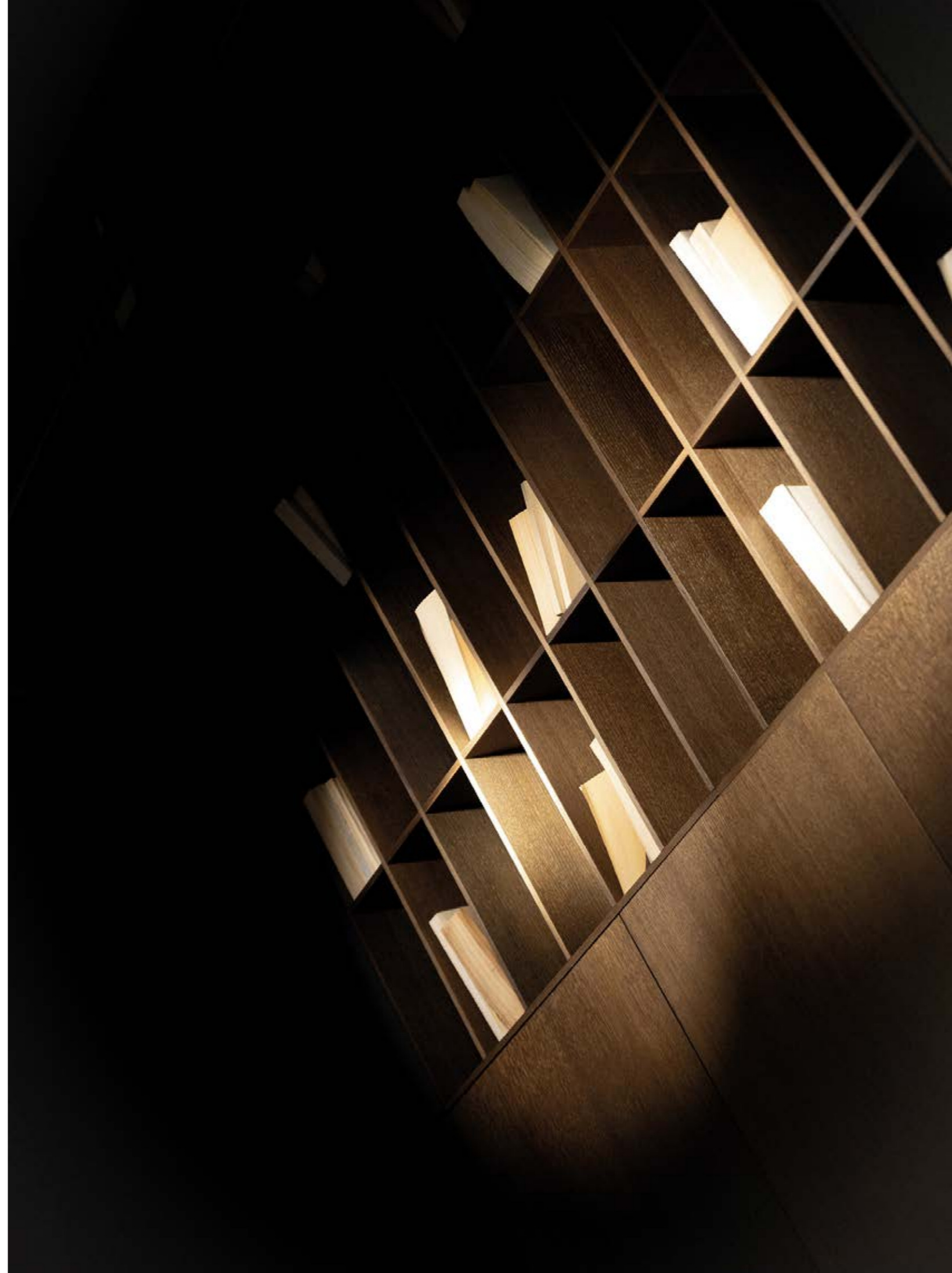

WE SEE CERAMICS AS AN EXTENSION
OF WHO WE ARE

EN.

Our creativity grows from embracing what is natural: the quiet beauty of imperfection, the respect we owe to the earth, and the purity of a material that speaks in its own voice. Each piece is born from that encounter where design meets the human soul—free, open, unforced. We innovate not only through design, but through the way we understand the world: through human value and the certainty that, together, we can create more than we ever could achieve alone. We are a team moved by passion, working in a shared rhythm, where every project becomes an opportunity to experience beauty, connection, and the quiet strength of being part of something greater.

There are no limits to a creative spirit willing to surrender to the art of shaping spaces. We believe in our people — in their clarity, their craft, their intention. And it is that shared truth, the beauty of who we are together, that guides everything we create.

ES.

Entendemos la cerámica como una extensión de nosotros mismos. Nuestra creatividad fluye al abrazar lo natural, la belleza de lo imperfecto, el respeto por la tierra y la pureza de un material que cuenta su propia historia. Cada pieza nace de esa inspiración que brota cuando el diseño se encuentra con el alma humana—sin barreras ni pretensiones. Innovamos no solo en diseño, sino en la forma de entender el mundo: desde el valor humano, desde la certeza de que juntos podemos crear mucho más de lo que lograríamos por separado. Somos un equipo movido por la pasión, trabajando a un mismo ritmo, donde cada proyecto se convierte en una oportunidad para experimentar la belleza, la conexión y la fuerza silenciosa de formar parte de algo más grande.

No hay límites para un espíritu creativo que se entrega al arte de transformar espacios. Creemos en nuestra gente—en su claridad, su oficio, su intención—y es esa verdad compartida, la belleza de lo que somos juntos, la que guía todo lo que hacemos.

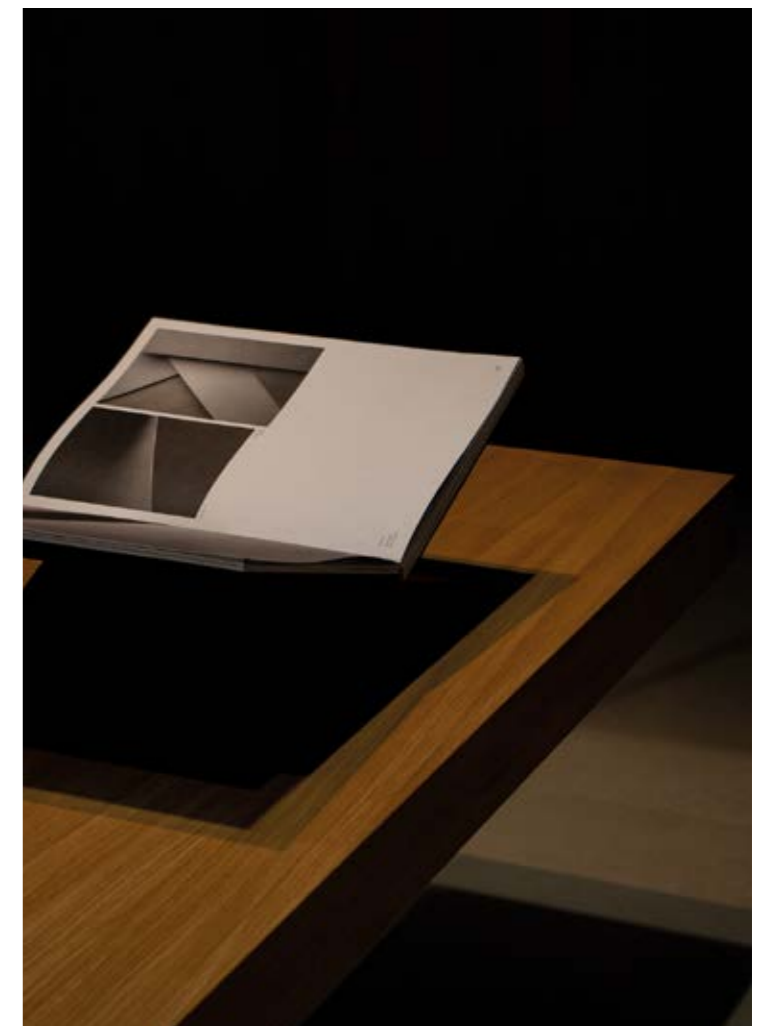



Milestones of our essence [01]

I	Technology	<i>3D Fit / Corelith / Ductile</i>	P. 25
II	Surfaces	<i>Soft Textured / Honed / Natural / BHAS / Anti-slip Horizon / Field / Blur / Breeze</i>	P. 33

Contemporary ceramic surfaces & Signature Surfaces [02]

P. 97
P. 169

The architecture of detail [03]

I	The production		P. 201
II	Technical solutions	<i>Mosaics / 20 mm / Technical pieces</i>	P. 205
III	Lithotech		P. 219
IV	Bathroom Furniture Series		P. 225
V	Custom Design Hub		P. 233
VI	Technical information		P. 245
VII	Sales conditions		P. 249

Contemporary ceramic surfaces

ALLURE P. 97
Marbled stone in ceramics
Piedra veteada cerámica

BERA&BEREN P. 101
Lusitan&Catalan limestone ceramics
Caliza Lusitana&Catalana cerámica

CUIT P. 107
Mud art in ceramics
Arte en barro cerámico

DUE P. 111
Natural brushed oak in ceramics
Roble natural cepillado en cerámica

FLOSS P. 113
Natural cement ceramics
Cemento natural cerámico

FRAME P. 115
Northern stone in ceramics
Piedra del norte cerámica

GROUND P. 119
Mixed surfaces ceramics
Mezcla de superficies cerámicas

GUBI P. 121
Microcement ceramics
Microcemento cerámico

KENDO P. 127
Jura stone in ceramics
Piedra Jura en cerámica

KORA P. 131
Wildwood in ceramics
Madera salvaje en cerámica

NOON P. 135
Northern stone in ceramics
Piedra del norte cerámica

KRON TECH P. 165
Concrete in ceramics
Cemento en cerámica

WEGA TECH P. 167
Volcanic stone in ceramics
Piedra volcánica cerámica

Wall & Floor Tiles
 PORCELAIN & DUCTILE

ODA P. 139
French stone in ceramics
Piedra francesa en cerámica

REM P. 143
Sawn wood in ceramics
Madera aserrada en cerámica

RIGA P. 145
Striped wood in ceramics
Madera rayada en cerámica

STILL P. 147
Microcement ceramics
Microcemento cerámico

UNO P. 151
Oak in ceramics
Roble en cerámica

VERSO CROSS CUT P. 153
Travertine stone in ceramics
Piedra travertino en cerámica

VERSO VEIN CUT P. 157
Travertine stone in ceramics
Piedra travertino en cerámica

VONN P. 161
Textured stone in ceramics
Piedra texturada en cerámica

Wall & Floor Tiles
 THROUGH-BODY PORCELAIN

Signature Surfaces

BALANCE P. 173
Designed by Victor Carrasco

CAVA P. 179
Designed by LucidiPevere

NUER P. 189
Designed by Kensaku Oshiro

Wall & Floor Tiles
 PORCELAIN & WHITE BODY



MILESTONES
OF OUR ESSENCE



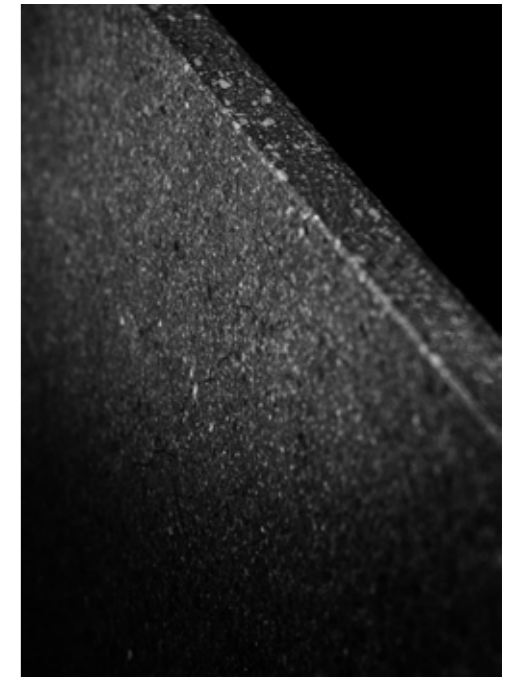

OUR TECHNOLOGY

[I]

EN.

Beauty does not begin at the surface. It arises much earlier: within the material, in the processes that remain unseen, in the quiet precision that turns an idea into something tangible. That is where everything starts. In work that does not seek attention, yet creates the ground on which our surfaces breathe, interact and reveal their character. Our technology is like this: discreet, rigorous, human at its core. It does not ask for attention; it enables it. It is the foundation from which every texture, every relief, every piece emerges. We innovate so that materials can express themselves more freely, allowing ceramics to move beyond imposed limits and become a language of their own – where finishes, veining, and reliefs emerge with the same naturalness found in the materials that inspire them.

Each advance brings us closer to what is essential: creating honest, durable and authentic surfaces. Because at Livingceramics, innovation is woven into every process, becoming a constant, quiet presence in our evolution.

ES.

La belleza no nace en la superficie. Surge mucho antes: en el interior del material, en los procesos que no se ven, en esa precisión silenciosa que convierte una idea en algo tangible. Es ahí donde comienza todo. En un trabajo que no busca protagonismo, pero sí ofrecer la base sobre la que nuestras superficies respiran, dialogan y revelan su carácter. Nuestra tecnología es así: discreta, rigurosa, profundamente humana. No reclama atención; la sostiene. Es la base sobre la que construimos cada textura, cada relieve, cada pieza. Investigamos para que la materia se exprese con más libertad. Para que la cerámica deje de imponerse como límite y se convierta en un lenguaje por sí mismo, donde acabados, veteados y relieves, existan con la misma naturalidad con la que aparecen en la propia naturaleza.

Cada avance es una forma de acercarnos a lo esencial: crear materiales honestos, duraderos y reales. Porque en Livingceramics, la innovación se integra en cada uno de nuestros procesos, convirtiéndose en una presencia continua en nuestra evolución.

EN

Our 3D-Fit technology allows relief and graphic design to work as one. They are not two layers interacting, but a single gesture born from the union between design and surface. Through an advanced graphic-injection technique, the texture follows the exact path of the material's drawing. The result is a surface of remarkable fidelity, where every vein, every grain, every transition feels authentic.

Its development enables us to reproduce the visual structure of the material with precision, creating a perfect correspondence between what you see and what you touch. This alignment between graphic and relief generates a deeper identity: the surface stops being representation and becomes experience— a material that expresses its truth with coherence and integrity.

3D-Fit offers the highest level of definition and realism.

ES

Nuestra tecnología 3D-Fit permite que el relieve y la gráfica trabajen al unísono.

No son dos capas que dialogan: es un único gesto que nace de la unión entre el diseño y la superficie. A través de una técnica avanzada de inyección gráfica, logramos que la textura siga exactamente el dibujo del material. El resultado es una superficie de una fidelidad sorprendente, donde cada veta, cada grano, cada transición se siente auténtica. Su desarrollo permite reproducir con exactitud la estructura visual del material, creando una correspondencia perfecta entre lo que se ve y lo que se toca. Esa alineación entre gráfica y relieve genera una identidad más profunda: la superficie deja de ser representación para convertirse en experiencia, en un material que expresa su verdad de manera íntegra y coherente.

3D-Fit nos ofrece el grado más alto de definición y realismo.





Corelith

EN.

Corelith is the technology that allows us to design technical porcelain from its core. Through the precise selection of components, proportions and granulometries, we create an interior that becomes a natural extension of the surface. There are no added layers, no artifices. The material remains coherent throughout its entire thickness, with an ultracompacted internal structure that ensures real continuity between graphic, texture and composition. This homogeneity results in superior chromatic stability and consistent resistance, even in cuts, machining and exposed edges.

Our technical porcelain collections behave as a continuous whole: a single language connecting the core, the surface and the edge without interruptions or visual discrepancies. Corelith allows each piece to be worked as a solid, honest and reliable block. And thanks to this technology, the possibilities multiply: worktops, volumes, exposed edges and architectural surfaces that demand visual continuity find their most refined expression.

ES.

Corelith es la tecnología que nos permite diseñar porcelánico técnico desde su núcleo. A partir de la selección precisa de componentes, proporciones y granulometrías, creamos un interior que se convierte en una extensión de la superficie. No hay capas añadidas, no hay artificios. El material es coherente en todo su espesor, con una estructura interna ultracompactada que garantiza una continuidad real entre gráfica, textura y composición. Esta homogeneidad se traduce en una estabilidad cromática superior y en una resistencia constante, incluso en cortes, mecanizados y cantos vistos.

Nuestras colecciones de porcelánico técnico se entienden como un todo continuo: un mismo lenguaje que conecta el núcleo con la superficie y el borde, sin interrupciones ni discrepancias visuales. Corelith permite trabajar la pieza como un bloque sólido, auténtico, fiable. Y gracias a esta técnica, las posibilidades se multiplican: encimeras, volúmenes, cantos vistos y superficies arquitectónicas que requieren continuidad visual encuentran aquí su mejor expresión.

EN

Ductile is our solution for making ceramic installation easier for professionals without compromising quality. Its special formulation allows precise cuts and perforations without effort and without generating stress within the material. Its large format and minimal thickness make installation faster and lighter, reducing construction times and offering optimal performance even in demanding projects.

Ductile simplifies both machining and placement, making the process more accessible, cleaner and more efficient. Thanks to this technology, ceramics gain versatility: they adapt naturally to interior cladding, construction details and bespoke solutions, always maintaining the aesthetic coherence and technical standards required by contemporary design.

ES

Ductile es nuestra solución para facilitar el trabajo del profesional sin renunciar a la calidad. Su formulación especial permite realizar cortes y perforaciones precisas sin esfuerzo y sin generar tensiones en el material. El gran formato y su mínimo espesor hacen que la instalación sea más ágil y ligera, reduciendo los tiempos de obra y ofreciendo un rendimiento óptimo incluso en proyectos exigentes.

Ductile simplifica tanto el mecanizado como la colocación, haciendo que el proceso sea más accesible, más limpio y más eficiente.

Gracias a esta tecnología, la cerámica gana en versatilidad: se adapta con facilidad a revestimientos interiores, detalles constructivos y soluciones a medida, manteniendo siempre la coherencia estética y el nivel técnico que requiere el diseño contemporáneo.

LIGHTER | MÁS LIGERO

Thanks to their slimline 6 mm thickness and new formula. Gracias a su espesor de 6 mm y a una nueva formulación cerámica.



SWIFTER | MÁS RÁPIDO

Their new formula offsets surface stress, making any cutting work much swifter and cleaner. | Su composición evita tensiones superficiales obteniendo cortes rápidos y limpios.



EASIER | MÁS FÁCIL

The tiles ductile properties make them easy to lay, avoiding the need for expensive tile adhesives. | La ductilidad de la pieza permite una instalación cómoda, evitando utilizar adhesivos de alto coste.



ECO-FRIENDLIER | MÁS ECOLÓGICO

Due to the big reduction in emissions from the manufacturing and transport processes. | Reducimos un gran número de emisiones en su fabricación y transporte.



SURFACES

[II]

EN.

From softness to depth, from texture to resilience, Livingceramics finishes embody different ways of inhabiting matter. Designed for varied contexts, they all share the same intention: to integrate seamlessly, preserve the harmony of the whole, and extend a visual language that is precise, essential and full of meaning.

Each finish offers a unique way of interacting with light and touch, shaping atmospheres that adapt naturally to the architecture they inhabit.

ES.

Cada acabado de Livingceramics transmite una manera de sentir la materia: suavidad, profundidad, relieve o firmeza. Pensados para distintos usos y contextos, todos comparten una misma vocación: integrarse con naturalidad, mantener la armonía del conjunto y dar continuidad a un lenguaje visual preciso, esencial y lleno de sentido.

En su encuentro con la arquitectura, estos acabados dialogan con la luz y el tacto, revelando matices que transforman el espacio con una belleza serena, casi intuitiva.

Soft Textured

EN

Fine relief aligned with the graphic using 3D-Fit technology, heightening material expression without overpowering it.

The perfect balance between tactile presence and visual harmony. Its subtle topography enriches the surface, enhancing depth, light interaction and the natural perception of the material while remaining gentle and restrained.

ES

Relieve sutil sincronizado con la gráfica mediante tecnología 3D-Fit, que intensifica la sensación matérica sin imponerse.

El equilibrio perfecto entre lo táctil y lo visual. Su ligera topografía enriquece la superficie, potenciando la profundidad, el juego de la luz y la lectura natural del material, siempre desde una presencia delicada y contenida.



Honed

EN

Silky-touch finish achieved through a delicate lapping process. It enhances realism and depth while preserving the digital relief of the original graphic. Its refined smoothness makes it ideal for interiors, where light and texture interact with a gentle, elegant continuity.

ES

Acabado sedoso al tacto, obtenido mediante un delicado proceso de lapado. Aporta realismo y profundidad visual, respetando el relieve digital de la gráfica original. Su suavidad precisa lo convierte en una opción perfecta para interiores, donde la luz y la materia se integran con una elegancia continua y equilibrada.

Img. Honed finish



Natural

EN

Smooth, matte surface that faithfully reflects the character of the original material. Its subtle softness reinforces the collection's timeless and understated nature. A discreet elegance runs through this finish, bringing harmony to any space without demanding attention.

ES

Superficie lisa y mate que reproduce con fidelidad el aspecto del material original. Su suavidad contenida refuerza el carácter sobrio y atemporal de la colección. Una elegancia discreta define este acabado, aportando armonía al espacio sin imponerse.

Bush Hammered

EN

A finish that shapes the surface through texture, adding visual depth and a more material-driven expression. The bush hammered effect creates an irregular relief that enriches the graphic and reinforces its tactile presence. Designed for projects seeking a more robust and expressive interpretation of the material.

ES

Un acabado que trabaja la superficie desde la textura, aportando profundidad visual y una lectura más matérica a la pieza. Este efecto abujardado genera un relieve irregular que enriquece la gráfica y refuerza su carácter táctil. Pensado para proyectos que buscan una expresión más robusta y expresiva del material.

Anti-Slip

EN

A slightly textured finish designed to ensure safety in wet or outdoor environments. Its anti-slip surface offers reliable performance while maintaining a refined appearance. Ideal for areas such as pool surrounds, terraces or showers, it delivers functionality without compromising the visual continuity or elegance of the collection.

ES

Acabado con una ligera rugosidad superficial para garantizar seguridad en zonas húmedas o exteriores. Su textura antideslizante mantiene la estética sin perder funcionalidad ni elegancia. Ideal para áreas como bordes de piscina, terrazas o duchas, combina un alto rendimiento con una presencia visual coherente y cuidada.

BHAS

Bush Hammered Anti-Slip

EN

A technical evolution of the Bush Hammered finish, conceived for environments where stability and safety are key. Its textured surface enhances grip while maintaining the depth and visual character of the material. This finish is specifically suited to outdoor settings and areas exposed to moisture or water.

ES

Evolución técnica del acabado Bush Hammered, diseñada para responder a contextos donde la seguridad y el agarre son prioritarios. La combinación de la textura abujardada con el acabado antideslizante incrementa la resistencia al deslizamiento. El resultado es un material ideal para aplicaciones exteriores y zonas en contacto con el agua.

Img. Bush Hammered finish



Img. Natural finish



Img. BHAS finish





Horizon

EN.
Horizon is a finish that naturally resonates with the essence of Oda. Its linear relief, developed using 3D-Fit® technology, reinforces the calm expression characteristic of timeless stones. The soft lines that traverse its surface create a deep, compelling rhythm, adding a tactile nuance that enriches its presence without overpowering it.

ES.
Horizon es un acabado que dialoga de manera natural con la esencia de Oda. Su relieve lineal, desarrollado mediante tecnología 3D-Fit refuerza esa lectura sosegada propia de las piedras clásicas. Su relieve lineal recorre su superficie creando un ritmo potente y profundo, añadiendo un matiz táctil que enriquece su presencia sin imponerse.

Field

EN.
Field emerges as a finish that enhances the contemporary expression of Gubi. Its matte surface and the linear relief generated through 3D-Fit® technology highlight the natural qualities of microcement, offering a soft and contained sense of depth. Field proposes a quiet presence that strengthens the architectural character of the original collection.

ES.
Field nace como un acabado que realza la expresión contemporánea de Gubi. Su superficie mate y el relieve lineal generado con tecnología 3D-Fit acentúan la naturalidad del microcemento, aportando una sensación de profundidad suave y contenida. Field plantea una presencia tranquila que refuerza el carácter arquitectónico de la colección original.

Blur

EN.
It preserves the nature of Still microcement, incorporating very fine irregular streaks. A texture that subtly emerges and fades, leaving behind an almost imperceptible trace that brings depth and naturalness without disturbing the balance of the surface.

ES.
Respeto la naturaleza del microcemento Still incorporando finísimos trazos irregulares. Una textura que aparece y desaparece, como una huella casi invisible, que aporta profundidad y naturalidad a la superficie sin alterar su equilibrio.

Breeze

EN.
It reflects a sensory softness that invites touch. A finish that plays with the linearity running across the Frame surface, suggesting hollows and voids with delicacy, without ever overstating them.

ES.
Refleja una suavidad sensorial que invita al tacto. Un acabado que juega con la linealidad que recorre la superficie de Frame, insinuando huecos y vacíos con delicadeza, sin subrayarlos en exceso.

Img. Oda Horizon finish



Img. Gubi Field finish



Img. Still Blur finish

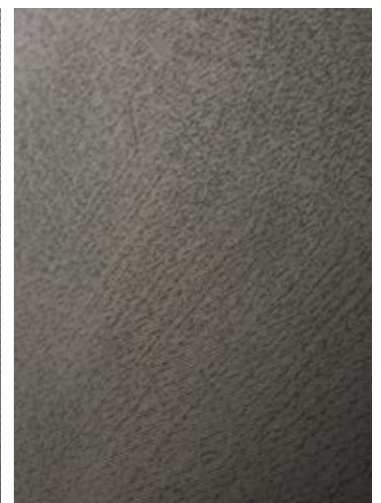

A GUIDE
TO THE COLLECTION

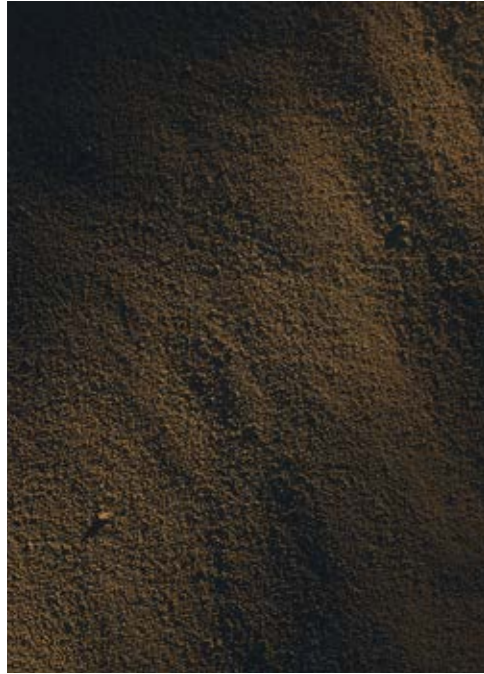



Imgs. Allure, Light Grey, Soft Textured





Img. Beren, Sand, Honed



Img. Beren, Sand, Natural



Imgs. Beren, Light Grey, Ductile Land



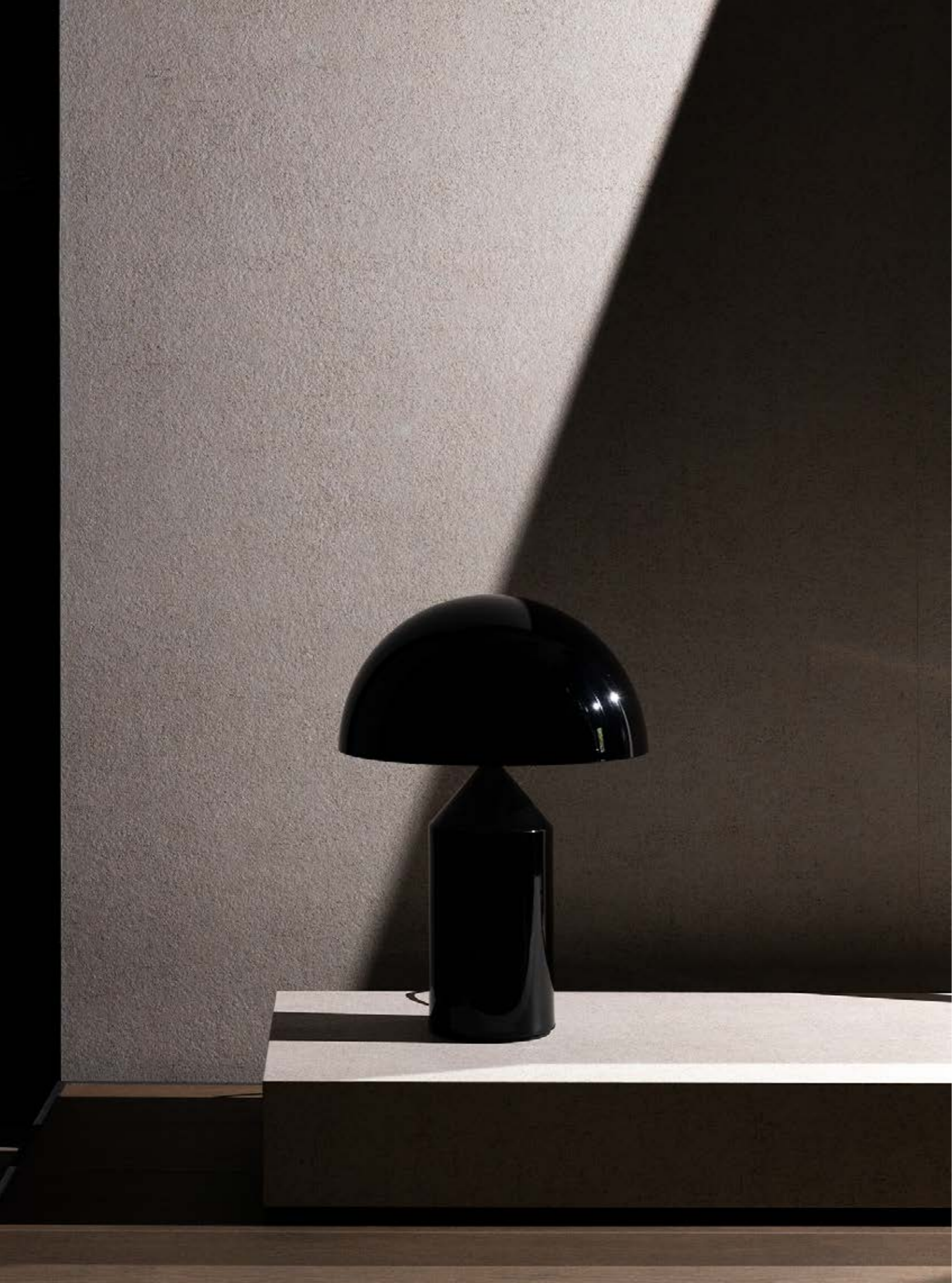

Imgs. Cuit, Bone, Soft Textured

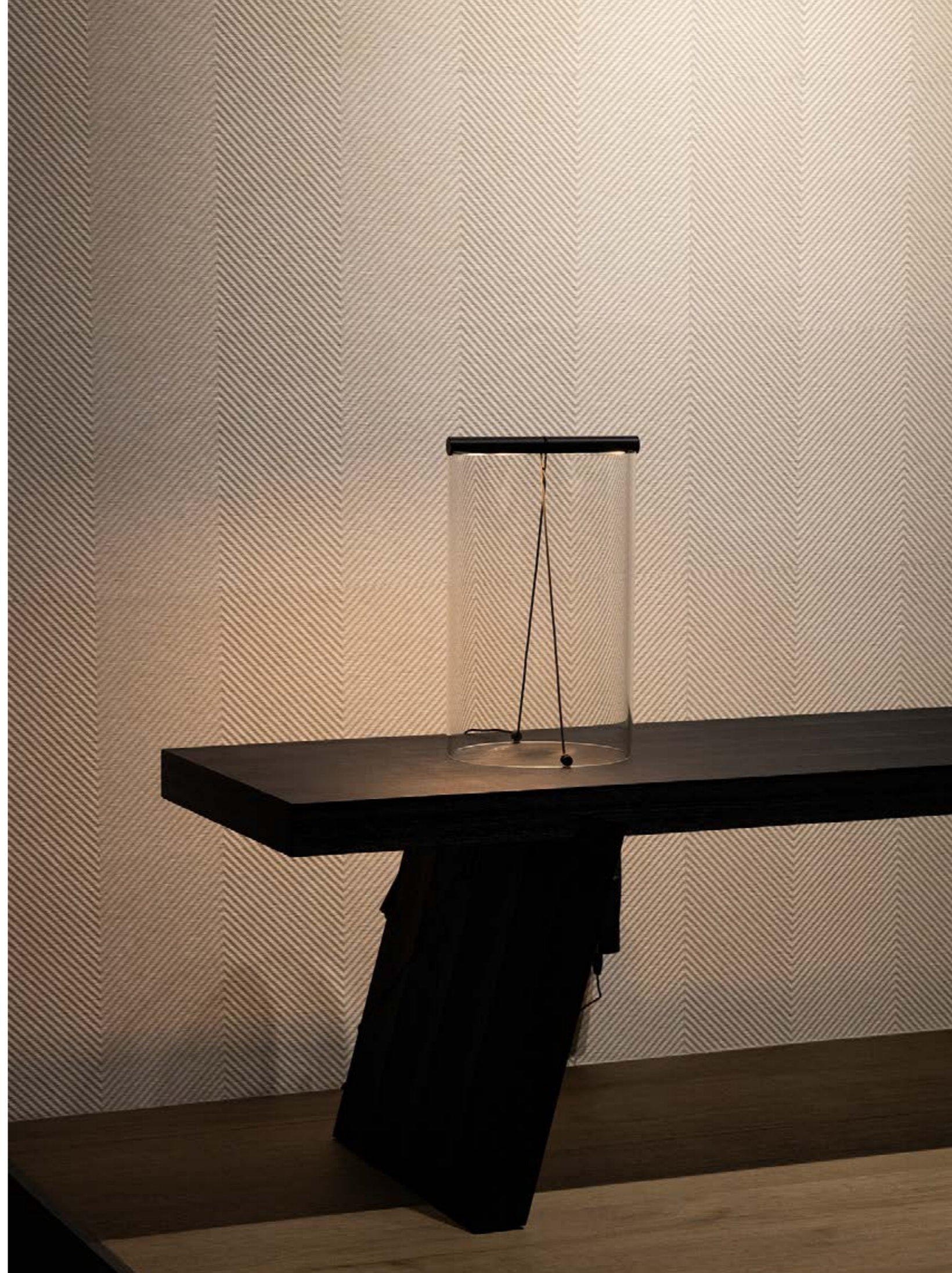





Imgs. Frame, Light, Honed





Img. Gubi, Ice, Honed



Img. Gubi, Light, Soft Textured



Img. Gubi, Light, Honed



Img. Gubi, Ice, Filo



Img. Kendo, Ice, Honed



Img. Kendo, Ice, Soft Textured



Img. Kendo, Ice, Soft Textured



Img. Kora, Sand, Soft Textured



Img. Kora, Walnut, Soft Textured



Img. Kora, Ductile reliefs Cozy & Cabana



Imgs. Noon, Anthracite, Soft Textured

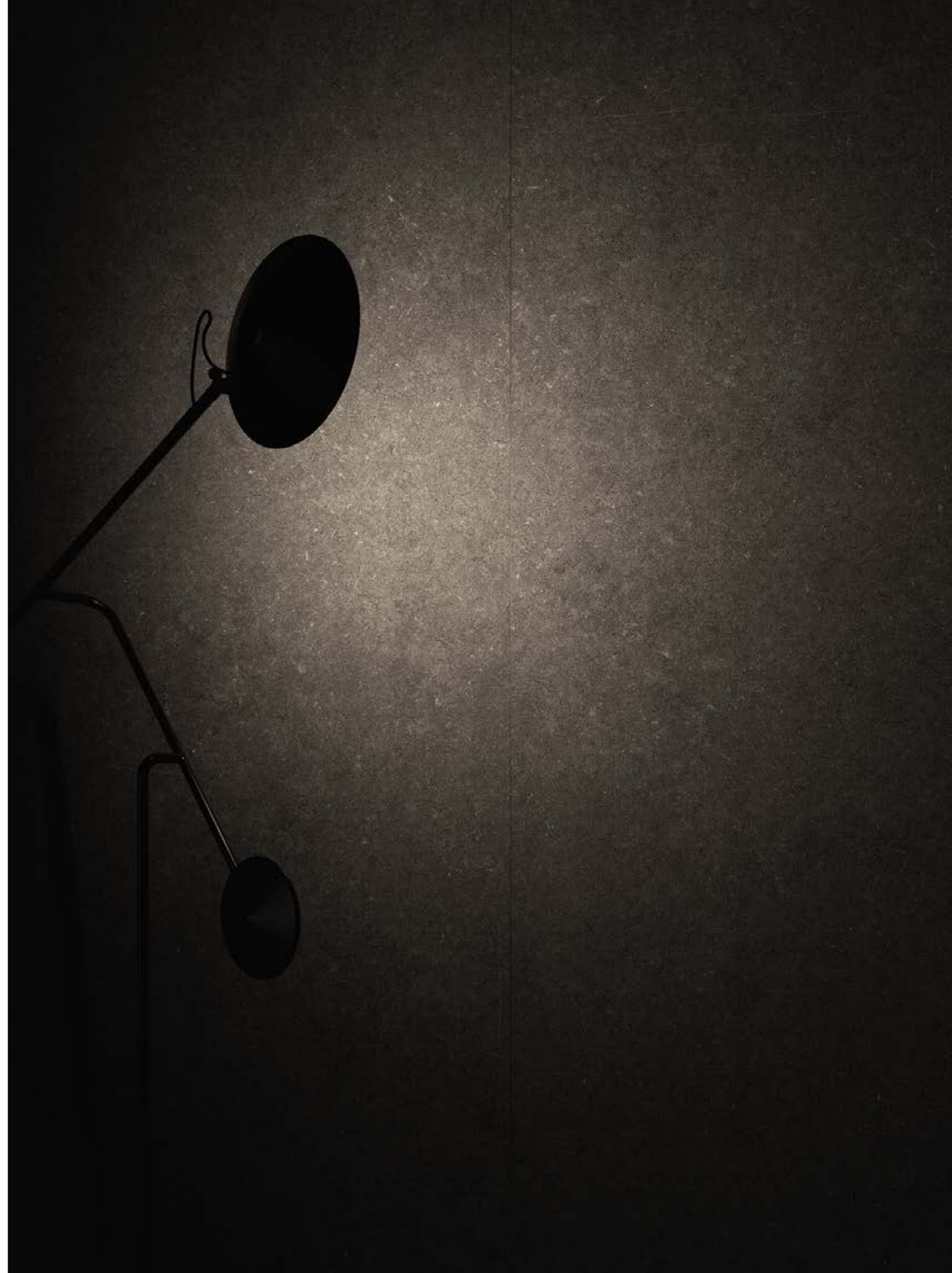

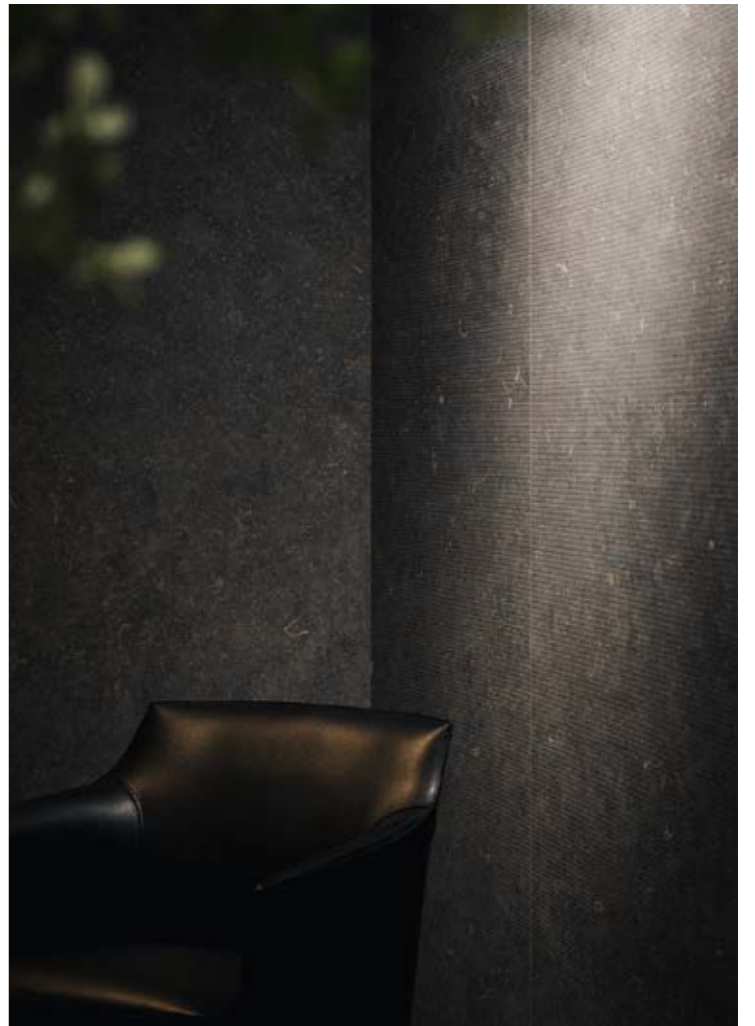

Img. Oda, Classic, Horizon



Imgs. Oda, Light, Honed



Imgs. Oda, Ice, BHAS



Img. Still, Cloud, Honed



Imgs. Still, Cloud, Soft Textured



Img. Still, Ice, Soft Textured

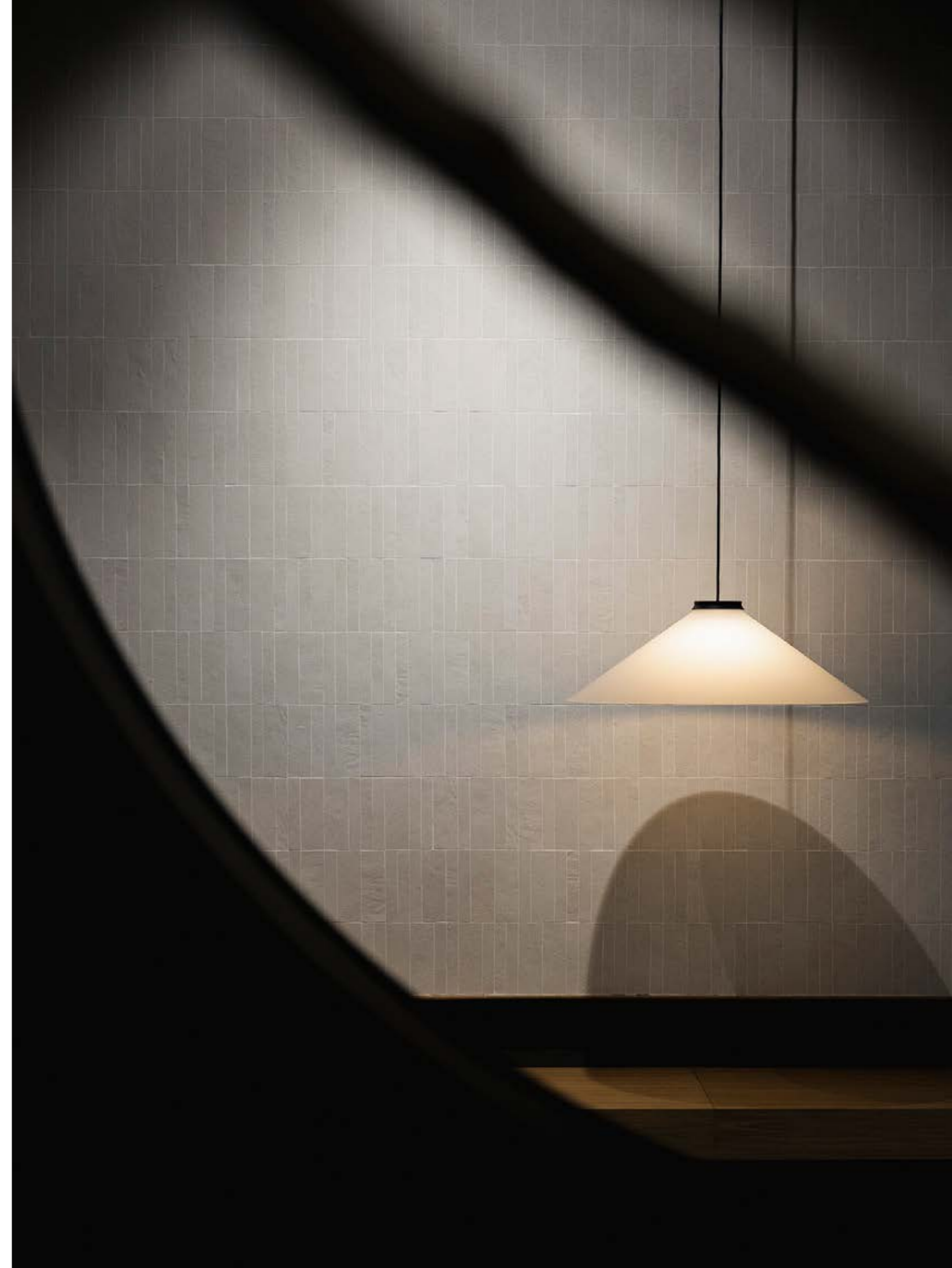

Img. Still, Ice, Custom mosaic



Img. Uno, Cognac, Soft Textured



Imgs. Uno, Cocoa, Soft Textured







Img. Verso Vein Cut, Light, Honed



Imgs. Vonn Anthracite



Img. Vonn, Light, Soft Textured



Img. Vonn, Light, Honed



Img. Voon, Light, Soft Textured



Imgs. Riga, Taupe

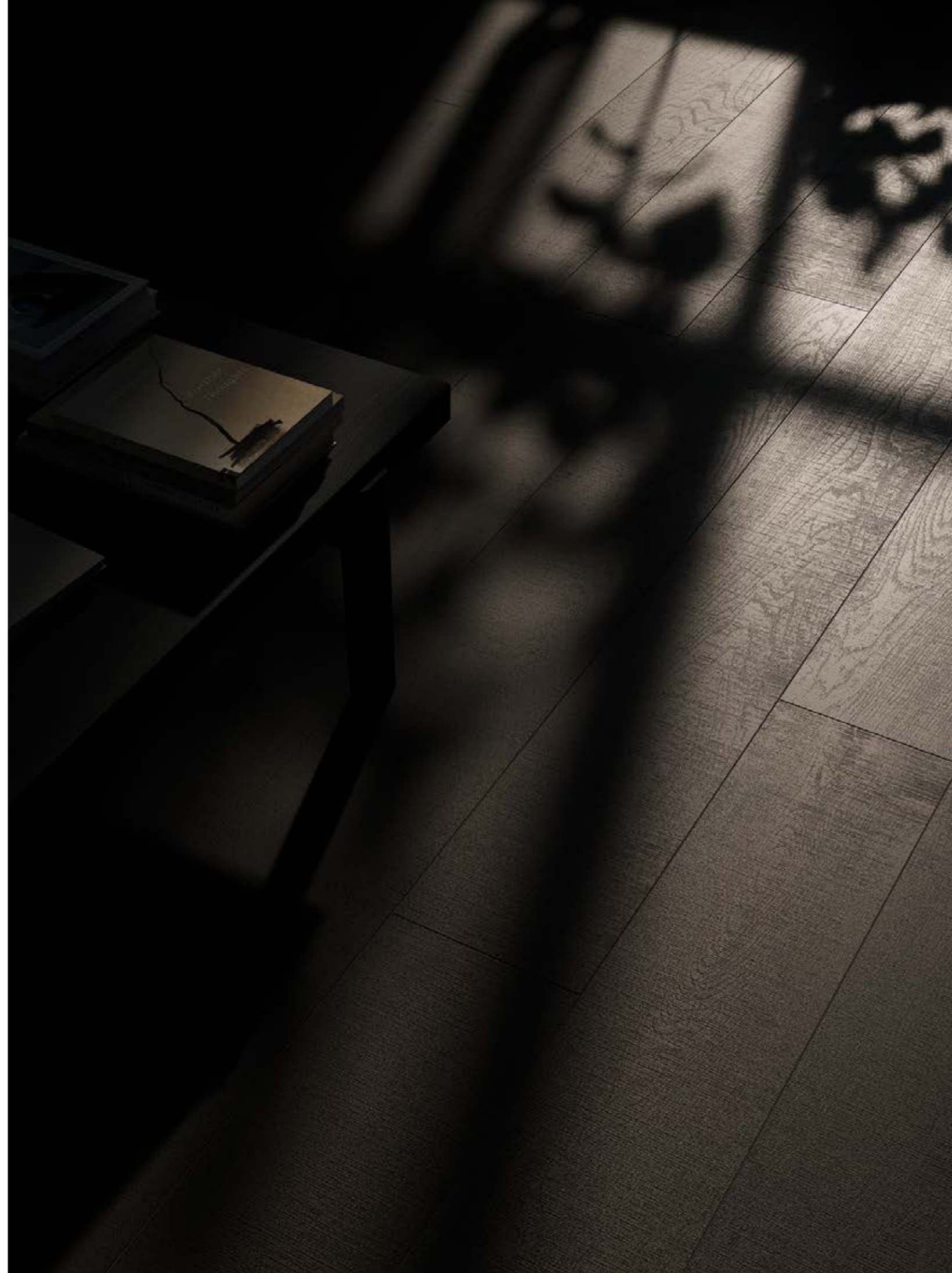

CONTEMPORARY CERAMIC SURFACES

A timeless expression of our essence

[02]

EN.

The catalogue you are holding, brings together the perfect harmony of design and technology, combining contemporary inspiration with technical excellence. Conceived as a clear and structured resource, it supports the way projects are imagined, specified and developed. Within these pages, materials are presented with a practical and architectural perspective, focusing on performance, compatibility and long-term reliability.

More than a source of inspiration, this catalogue is designed to assist decision-making and to accompany professionals in the creation of spaces that respond precisely to the demands of contemporary architecture and interior design.

ES.

A través de estas páginas, nuestro catálogo expresa el equilibrio perfecto entre diseño y tecnología, entre inspiración contemporánea y especificaciones técnicas. Concebido como una herramienta clara y estructurada, acompaña la manera en que los proyectos se imaginan, se definen y se desarrollan. Aquí, los materiales se presentan desde una mirada práctica y arquitectónica, atendiendo a su comportamiento, compatibilidad y fiabilidad a largo plazo.

Más allá de la inspiración, este catálogo está pensado para facilitar la toma de decisiones y acompañar la creación de espacios acordes a las exigencias de la arquitectura y el interiorismo contemporáneos.



PORCELAIN & DUCTILE

ALLURE

Marbled stone in ceramics
Piedra veteadá cerámica



BERA&BEREN

Lusitan&Catalan limestone ceramics
Caliza Lusitana&Catalana cerámica



CUIT

Mud art in ceramics
Arte en barro cerámico



DUE

Natural brushed oak in ceramics
Roble natural cepillado en cerámica



FLOSS

Natural cement ceramics
Cemento natural cerámico



FRAME

Northern stone in ceramics
Piedra del norte cerámica



GROUND

Mixed surfaces ceramics
Mezcla de superficies cerámicas



GUBI

Microcement ceramics
Microcemento cerámico



KENDO

Jura stone in ceramics
Piedra Jura en cerámica



KORA

Wildwood in ceramics
Madera salvaje en cerámica

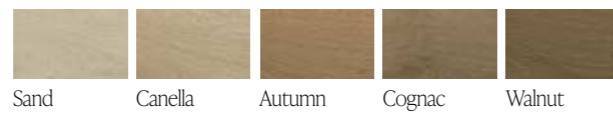

NOON

Northern stone in ceramics
Piedra del norte cerámica



ODA

French stone in ceramics
Piedra francesa en cerámica



REM

Sawn wood in ceramics
Madera aserrada en cerámica



RIGA

Striped wood in ceramics
Madera rayada en cerámica



STILL

Microcement ceramics
Microcemento cerámico



UNO

Oak in ceramics
Roble en cerámica



VERSO CROSS CUT

Travertine stone in ceramics
Piedra travertino en cerámica



VERSO VEIN CUT

Travertine stone in ceramics
Piedra travertino en cerámica



VONN

Textured stone in ceramics
Piedra texturada en cerámica

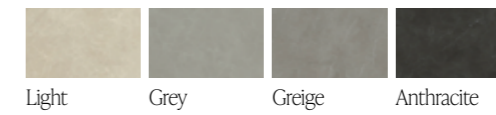

THROUGH-BODY PORCELAIN

KRON TECH

Concrete in ceramics
Cemento en cerámica



WEGA TECH

Volcanic stone in ceramics
Piedra volcánica cerámica



Signature Surfaces

PORCELAIN & WHITE BODY

BALANCE

Designed by Víctor Carrasco



CAVA

Designed by LucidiPevere



NUER

Designed by Kensaku Oshiro



	120x270 48"x106"	Ductile 90x270 36"x106"	Ductile 60x120 24"x48"	Duc. Relief 60x120 24"x48"	Duc. Relief 30x90 12"x36"	22.5x200 9"x79"	22.5x160 9"x63"	120x120 48"x48"	60x120 24"x48"	20x120 8"x48"	15x120 6"x48"	10x120 4"x48"	90x90 36"x36"	45x90 18"x36"	60x60 24"x24"	30x60 12"x24"	10x60 4"x24"	5x60 2"x24"
ALLURE	*	*			*			*	*				*	*	*	*		
BERA&BEREN	*	*	*	*	*			*	*				*	*	*	*	*	*
CUIT	*	*	*	*				*	*				*	*	*	*		
DUE						*	*			*								
FLOSS	*	*						*	*				*	*	*	*	*	*
FRAME	*	*	*	*				*	*				*	*	*	*		
GROUND					*													
GUBI	*	*	*	*	*			*	*				*	*	*	*	*	*
KENDO	*	*	*	*				*	*				*	*	*	*		
KORA				*		*	*			*								
NOON	*	*	*	*				*	*				*	*	*	*		
ODA	*	*	*	*				*	*				*	*	*	*		
REM											*	*						*
RIGA						*	*			*								
STILL	*	*	*	*				*	*				*	*	*	*		
UNO						*	*			*								
VERSO CROSS CUT	*	*	*	*				*	*				*	*	*	*		
VERSO VEIN CUT	*	*	*	*				*	*				*	*	*	*		
VONN	*	*	*	*				*	*				*	*	*	*		
KRON TECH								*	*									
WEGA TECH								*	*									

	60x120 24"x48"	90x90 36"x36"	45x90 18"x36"	60x60 24"x24"	30x60 12"x24"	10x60 4"x24"	15x30 6"x12"	7.5x30 3"x12"	13x15 5"x6"	10x10 4"x4"	5x30 2"x12"	5x15 2"x6"
BALANCE										*	*	*
CAVA		*	*	*	*	*	*	*	*			
NUER	*											

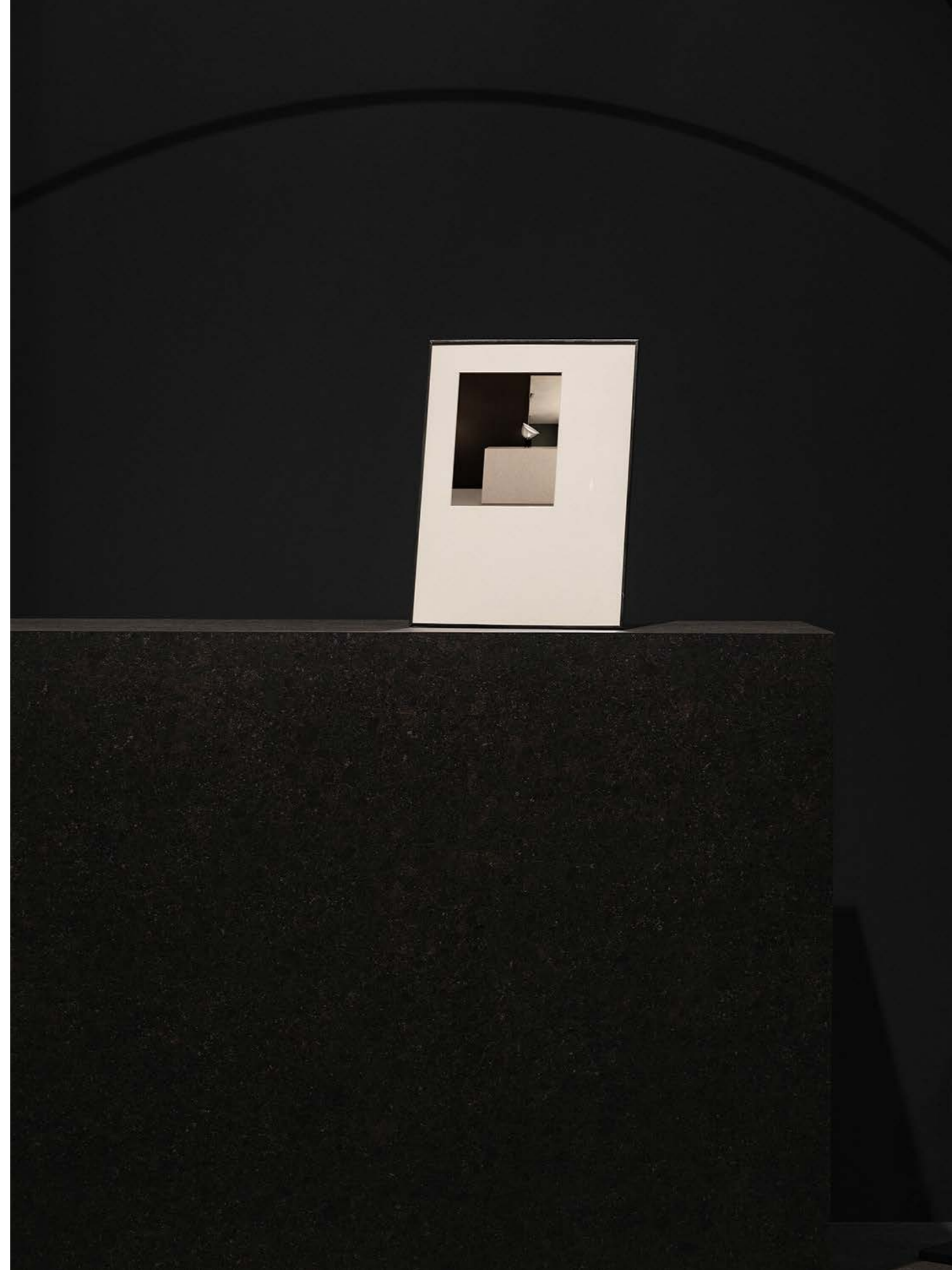

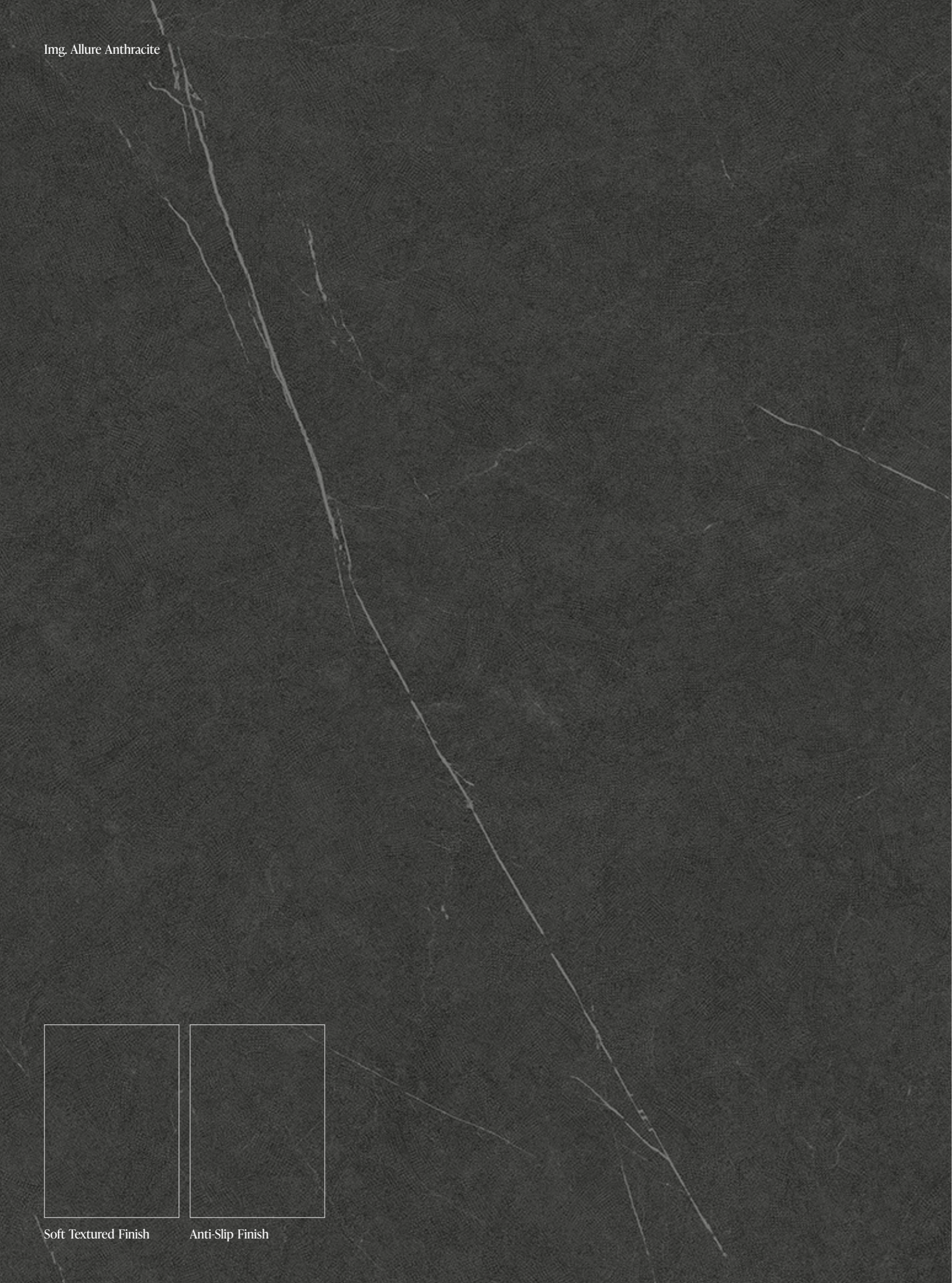

Colours available.
Colores disponibles.

Available sizes & finishes.
Formatos y acabados disponibles.

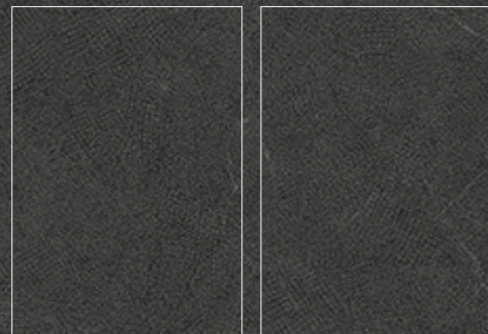

Soft Textured Finish

Anti-Slip Finish

Color Body Porcelain & Ductile 90x270 - Porcelánico Masa Coloreada & Ductile 90x270

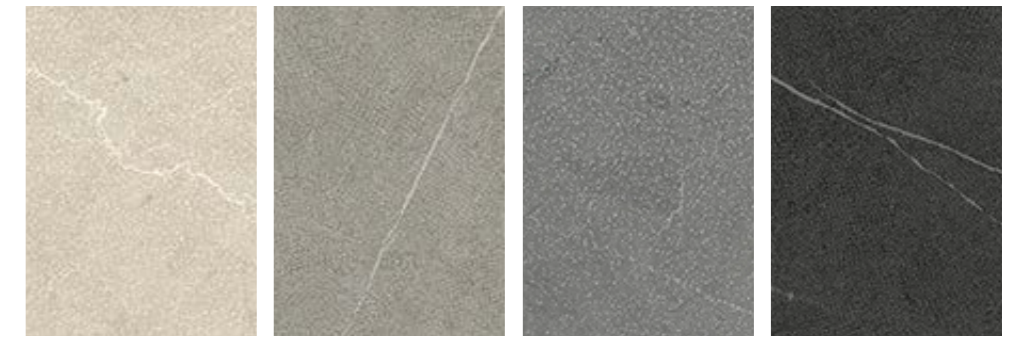

Sand *

Light Grey *

Grey

Anthracite *

Destonified | Destonificado V.2

* 20mm thickness colours | Colores para 20mm

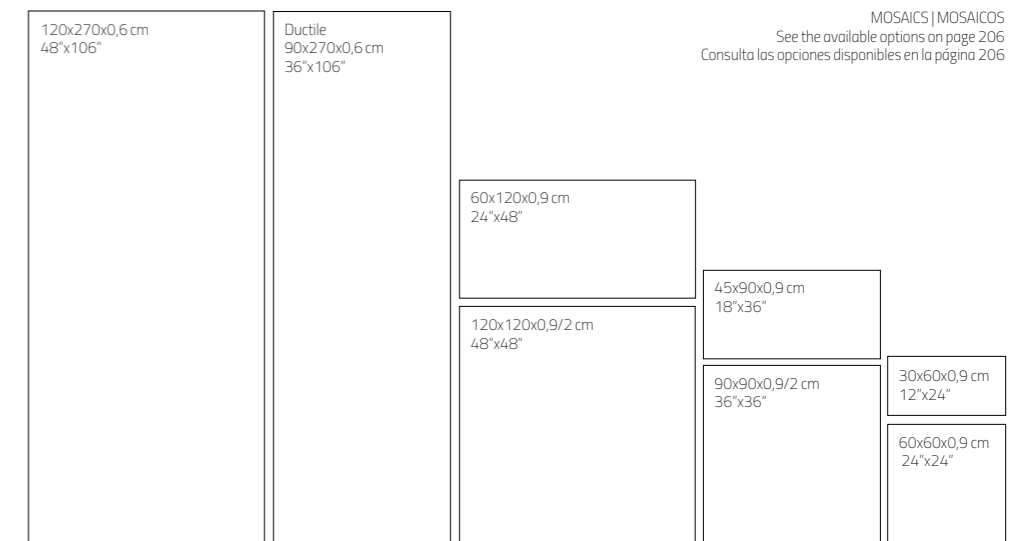

Rectified - Rectificado
120x270: 7 - 90x270: 7 - 120x120: 14 - 60x120: 14 - 90x90: 16 - 45x90: 32 - 60x60: 28 - 30x60: 56

Nominal Size Formato Nominal	Real Size Formato Real	Soft Textured C1 - R9 - CA	Anti-Slip C3 - R11 - CC	Price Code	Pz/Box	M2/Box	Kg/Box	Box/Pa	M2/Pa	Kg/Pa
Porcelain Tiles										
30x60 cm 12"x24"	29,8x59,8x0,9 cm	•	•	30	6	1,07	22,29	48	51,36	1110
60x60 cm 24"x24"	59,8x59,8x0,9 cm	•	•	60	3	1,07	22,45	48	51,36	1110
45x90 cm 18"x36"	44,8x89,8x0,9 cm	•	•	45	3	1,21	25,22	48	57,93	1236
90x90 cm 36"x36"	89,8x89,8x0,9 cm	•	•	90	2	1,61	33,79	30	48,30	1039
90x90x2 cm 36"x36"	89,8x89,8x2 cm	•	•	94	1	0,81	37,49	30	24,15	1170
60x120 cm 24"x48"	59,8x119,8x0,9 cm	•	•	62	2	1,43	29,95	36	51,48	1110
120x120 cm 48"x48"	119,8x119,8x0,9 cm	•	•	120	1	1,44	30,11	40	57,41	1259
120x120x2 cm 48"x48"	119,8x119,8x2 cm	•	•	121	1	1,44	66,02	16	22,96	1140
120x270 cm 48"x106"	119,8x269,8x0,6 cm	•	•	276	1	3,23	45,50	24	77,52	1222
Ductile										
90x270 cm 36"x106"	89,8x269,8x0,6 cm	•	•	970	1	2,42	29,04	24	58,08	801

Img. Allure Anthracite Line



Img. Allure Anthracite Wave



Img. Allure Anthracite Wiggle

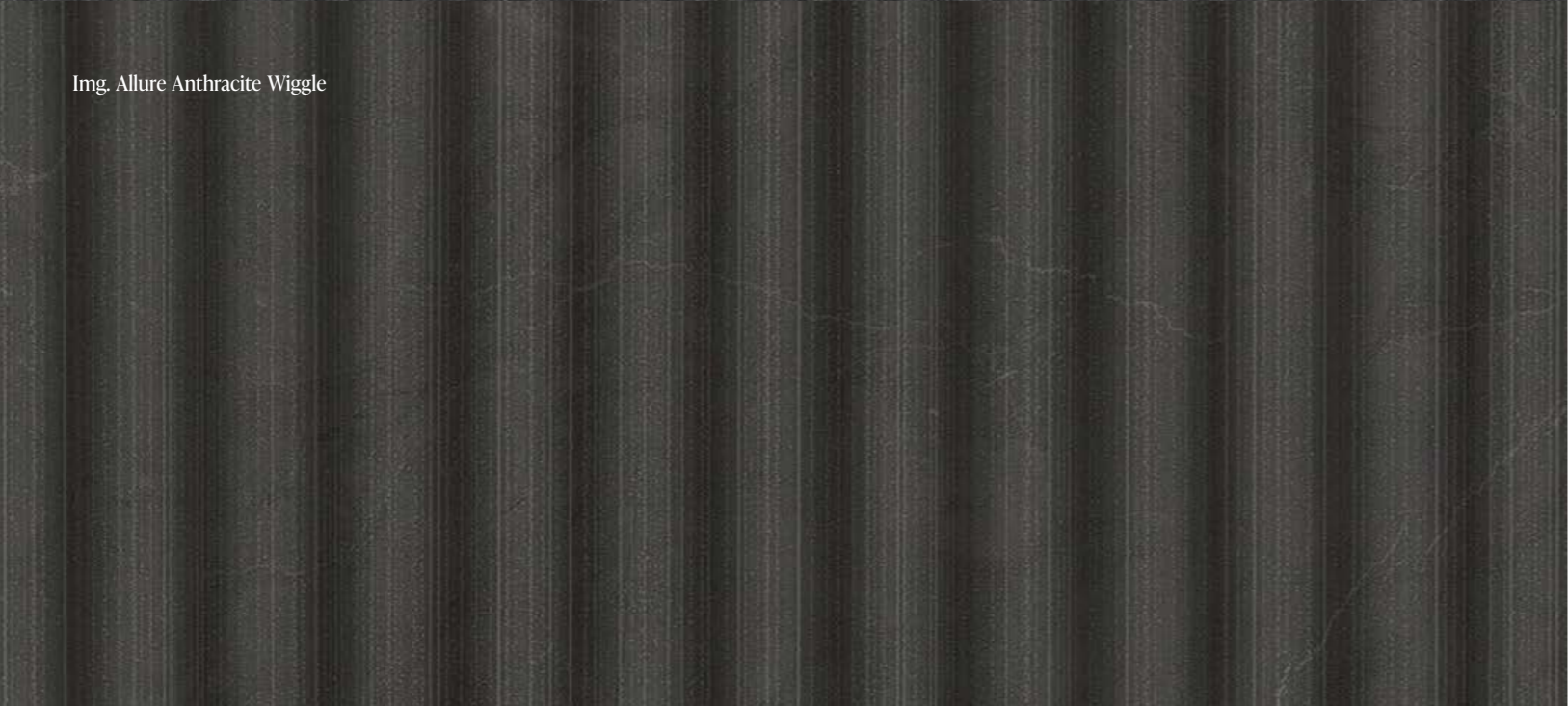

Allure Ductile

Marbled stone in ceramics | *Piedra veteadada cerámica*

Colours available.
Colores disponibles.

White Body - Pasta blanca



White



Light Grey

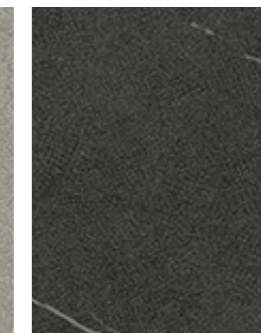

Anthracite

Destonified | Destonificado V.2

Available sizes & finishes.
Formatos y acabados disponibles.

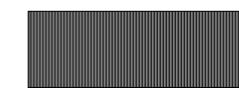

Line

30x90x0,9 cm
12"x36"

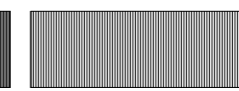

Wave

30x90x0,9 cm
12"x36"

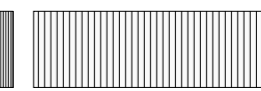

Wiggle

30x90x0,9 cm
12"x36"

Rectified - Rectificado

Number of designs by format: | Número de diseños por formato: 30x90: 16

Nominal Size Formato Nominal	Real Size Formato Real	Line	Wave	Wiggle	Pice Code	Pz Box	M2 Box	Kg Box	Box Pa	M2 Pa	Kg Pa
30x90 cm 12"x36"	29,8x89,8x0,9 cm	•	•	•	320	4	1,07	17,60	54	57,78	954



Colours available.
Colores disponibles.

Available sizes & finishes.
Formatos y acabados disponibles.

Bera&Beren

Lusitan & Catalan Limestone ceramics
Piedra Lusitana & Catalana cerámica

Color Body Porcelain & Ductile 90x270 - Porcelánico Masa Coloreada & Ductile 90x270

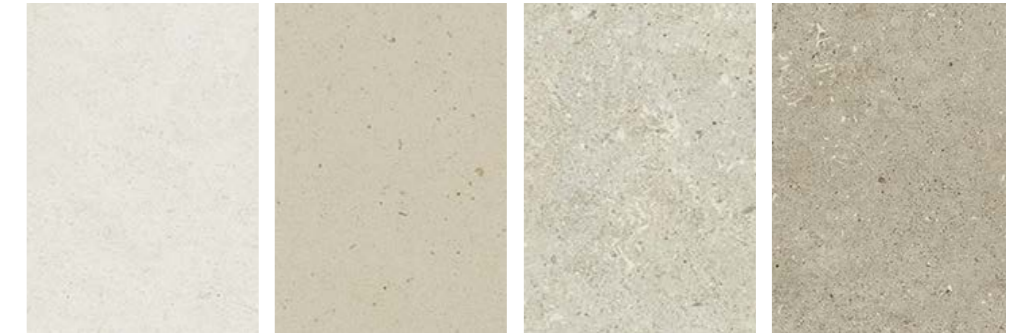

Bera Ice Bera White * Beren Sand * Beren Light Grey *



Beren Biscuit * Beren Greige * Beren Dark Grey * Beren Black

Destonified | Destonificado V.2

* 20mm thickness colours | Colores para 20mm

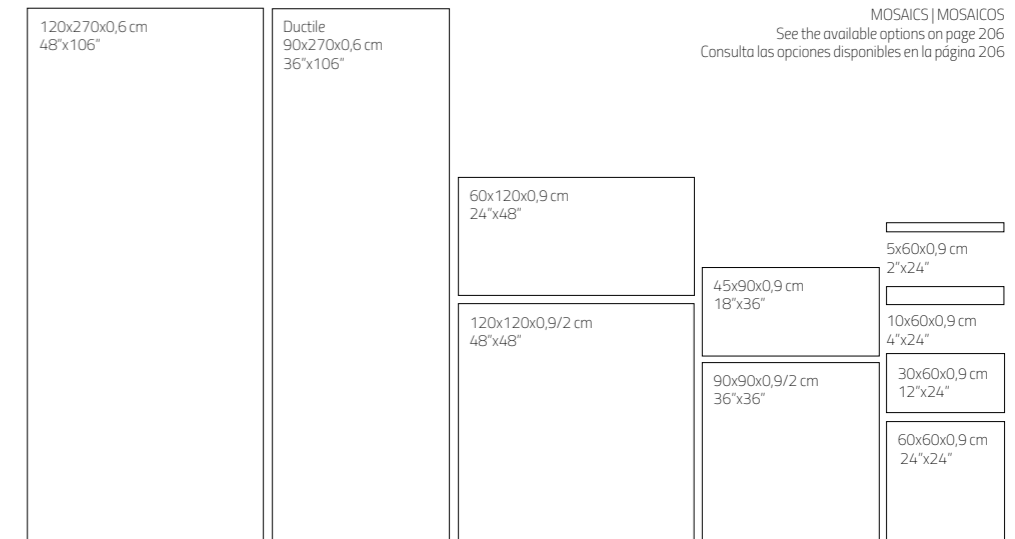

Rectified - Rectificado 120x270: 7 - 90x270: 7 - 120x120: 14 - 60x120: 14 - 90x90: 16 - 45x90: 32 - 60x60: 28 - 30x60: 56 - 10x60: 168 - 5x60: 336

Number of designs by format: | Número de diseños por formato:



Soft Textured Finish Honed Finish Natural Finish Bush Hammered Finish Anti-Slip Finish

Nominal Size Formato Nominal	Real Size Formato Real	Soft Textured C2 R10 CB	Honed	Natural C1 R9 CA	B H C2 R10 CB	AS C3 R11 CC	Price Code	Pz/ Box	M2/ Box	Kg/ Box	Box/ Pa	M2/ Pa	Kg/ Pa	
Porcelain Tiles														
5x60 cm 2"x24"	4,8x59,8x0,9 cm			•	•	•	5	20	0,57	13,20	60	34,44	832	
10x60 cm 4"x24"	9,8x59,8x0,9 cm			•	•	•	10	10	0,59	13,30	60	35,40	838	
30x60 cm 12"x24"	29,8x59,8x0,9 cm			•	•	•	30	6	1,07	22,29	48	51,36	1110	
60x60 cm 24"x24"	59,8x59,8x0,9 cm			•	•	•	60	3	1,07	22,45	48	51,36	1110	
45x90 cm 18"x36"	44,8x89,8x0,9 cm			•	•	•	45	3	1,21	25,22	48	57,93	1236	
90x90 cm 36"x36"	89,8x89,8x0,9 cm	•	•	•	•	•	90/90H	2	1,61	33,79	30	48,30	1039	
90x90x2 cm 36"x36"	89,8x89,8x2 cm			•	•	•		94	1	0,81	37,69	30	24,15	1170
60x120 cm 24"x48"	59,8x119,8x0,9 cm	•	•	•	•	•	62/62H	2	1,43	29,95	36	51,48	1110	
120x120 cm 48"x48"	119,8x119,8x0,9 cm	•	•	•	•	•	120/120H	1	1,44	30,11	40	57,41	1259	
120x120x2 cm 48"x48"	119,8x119,8x2 cm			•	•	•		121	1	1,44	66,02	16	22,96	1140
120x270 cm 48"x106"	119,8x269,8x0,6 cm	•	•	•			276/276H	1	3,23	45,50	24	77,52	1222	
Ductile														
90x270 cm 36"x106"	89,8x269,8x0,6 cm			•			970	1	2,42	29,04	24	58,08	801	

Img. Beren Light Grey Dot



Img. Beren Light Grey Saw

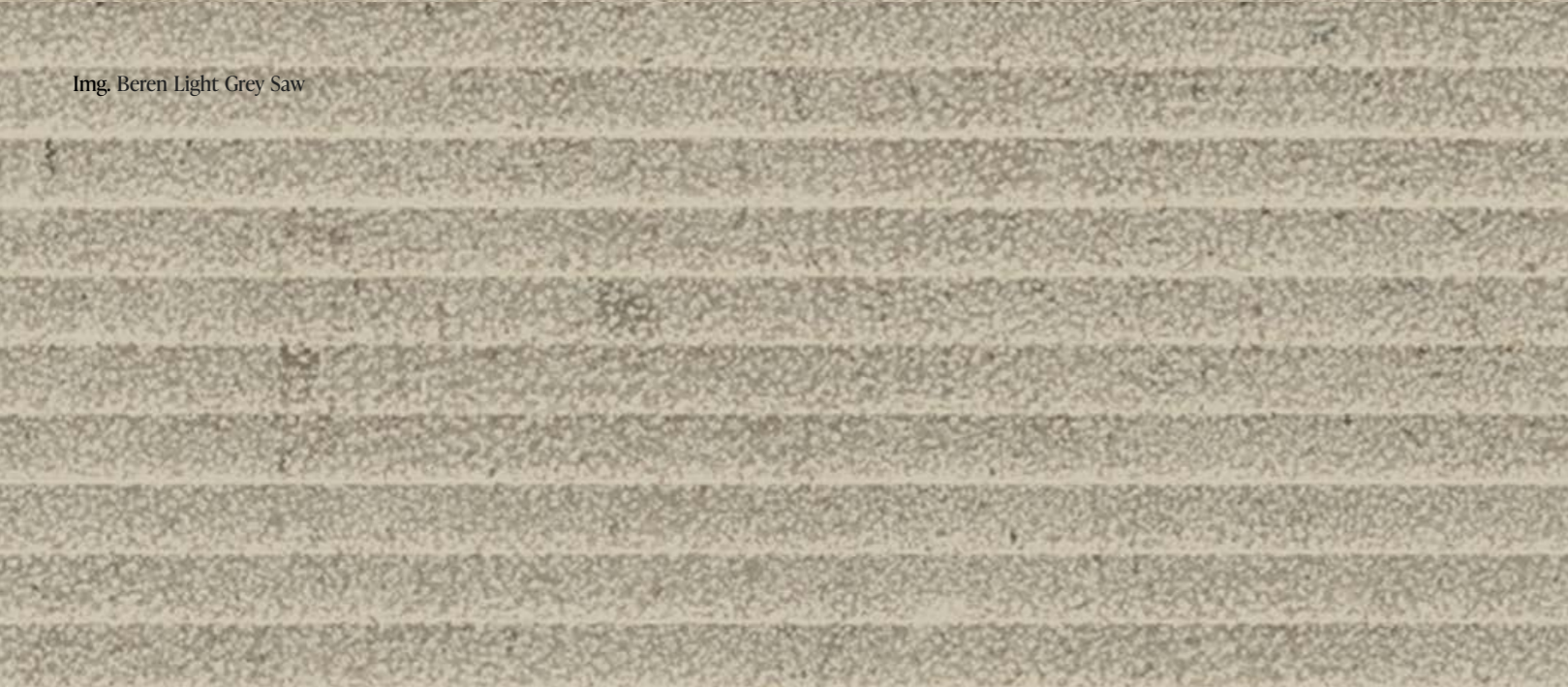

Img. Beren Light Grey Six



Bera&Beren Ductile

Lusitan & Catalan Limestone ceramics
Piedra Lusitana & Catalana cerámica

Colours available.
Colores disponibles.

White Body - Pasta blanca



Bera White

Beren Light Grey

Beren Biscuit

Beren Dark Grey

Available sizes & finishes.
Formatos y acabados disponibles.

Destonified | Destonificado V.2

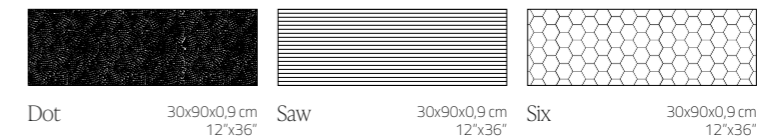

Dot

30x90x0,9 cm
12"x36"

Saw

30x90x0,9 cm
12"x36"

Six

30x90x0,9 cm
12"x36"

Rectified - Rectificado

Number of designs by format: | Número de diseños por formato: 30x90: 16

Nominal Size Formato Nominal	Real Size Formato Real	Dot	Saw	Six	Pice Code	Pz Box	M2 Box	Kg Box	Box Pa	M2 Pa	Kg Pa
30x90 cm 12"x36"	29,8x89,8x0,9 cm	•	•	•	320	4	1,07	17,60	54	57,78	974

Colours available.
Colores disponibles.

White Body - Pasta blanca



Bera Ice

Bera White

Beren Sand

Beren Light Grey

Destonified | Destonificado V.2

Available sizes & finishes.
Formatos y acabados disponibles.

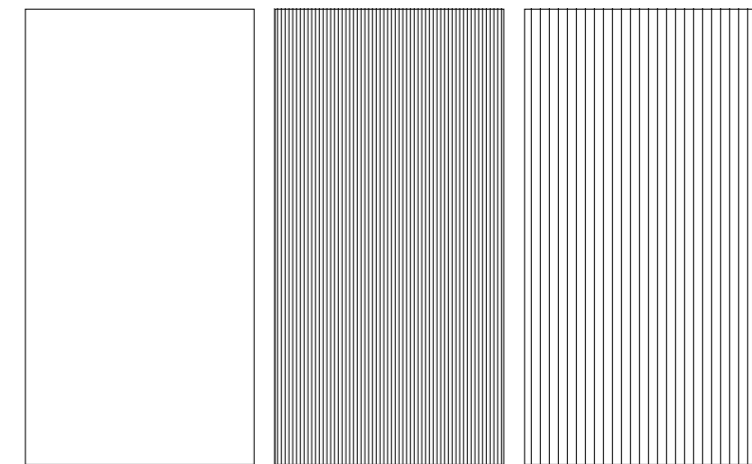

Base

60x120x0,6 cm
24"x48"

Lane

60x120x0,9 cm
24"x48"

Land

60x120x0,9 cm
24"x48"

Rectified - Rectificado

Number of designs by format: | Número de diseños por formato: 60x120: 14-24

Nominal Size Formato Nominal	Real Size Formato Real	Natural	Soft Textured	Lane	Land	Pice Code	Pz Box	M2 Box	Kg Box	Box Pa	M2 Pa	Kg Pa
60x120 cm. 24"x48"	59,8x119,8x0,6 cm	•	•			620	3	2,15	26,20	35	75,07	947
60x120 cm 24"x48"	59,8x119,8x0,9 cm			•	•	620	2	1,43	22,00	35	50,05	800



Colours available.
Colores disponibles.

Available sizes & finishes.
Formatos y acabados disponibles.



Soft Textured Finish

Anti-Slip Finish

Cuit

Color Body Porcelain & Ductile 90x270 - Porcelánico Masa Coloreada & Ductile 90x270

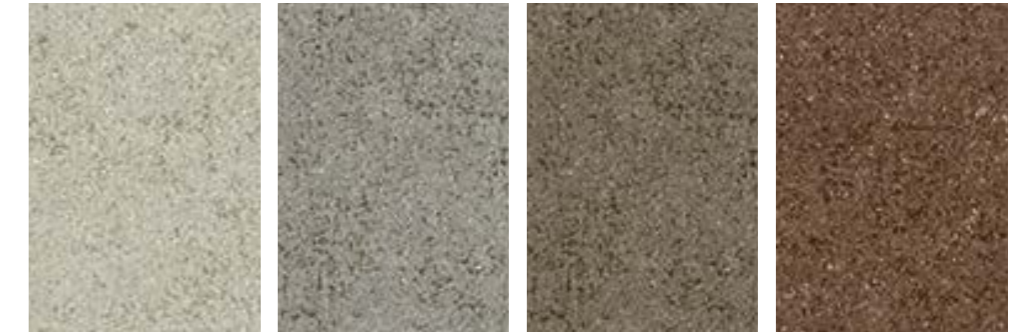

Bone

Grey

Clay

Terra



Charcoal

Destonified | Destonificado V.2

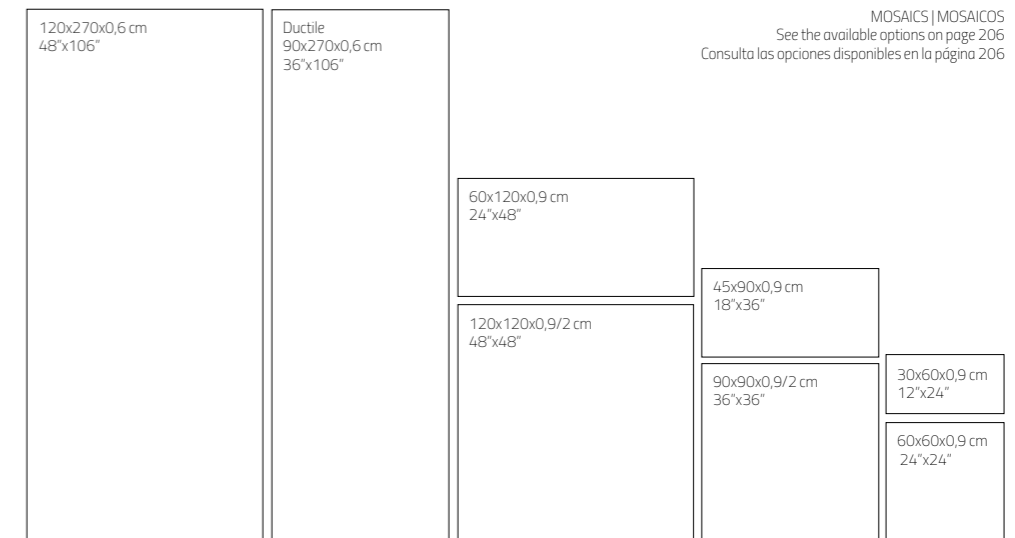

Rectified - Rectificado

Number of designs by format | Número de diseños por formato:
120x270: 7 - 90x270: 7 - 120x120: 14 - 60x120: 24 - 90x90: 16 - 45x90: 32 - 60x60: 48 - 30x60: 96

Nominal Size Formato Nominal	Nominal Size Formato Nominal	Soft Textured C2-R10-CB	Anti-Slip C3-R11-CC	Price Code	Pz Box	M2 Box	Kg Box	Box Pa	M2 Pa	Kg Pa
Porcelain Tiles										
30x60 cm 12"x24"	29,8x59,8x0,9 cm.	•	•	30	6	1,07	22,29	48	51,36	1110
60x60 cm 24"x24"	59,8x59,8x0,9 cm.	•	•	60	3	1,07	22,45	48	51,36	1110
45x90 cm 18"x36"	44,8x89,8x0,9 cm.	•	•	45	3	1,21	25,22	48	57,93	1236
90x90 cm 36"x36"	89,8x89,8x0,9 cm.	•	•	90	2	1,61	33,79	30	48,30	1039
60x120 cm 24"x48"	59,8x119,8x0,9 cm.	•	•	62	2	1,43	29,95	36	51,48	1110
120x120 cm 48"x48"	119,8x119,8x0,9 cm.	•	•	120	1	1,44	30,11	40	57,41	1259
120x270 cm 48"x106"	119,8x269,8x0,6 cm.	•	•	276	1	3,23	45,50	24	77,52	1222
Ductile										
90x270 cm 36"x106"	89,8x269,8x0,6 cm.	•	•	970	1	2,42	29,04	24	58,08	801

Colours available.
Colores disponibles.

White Body - Pasta blanca

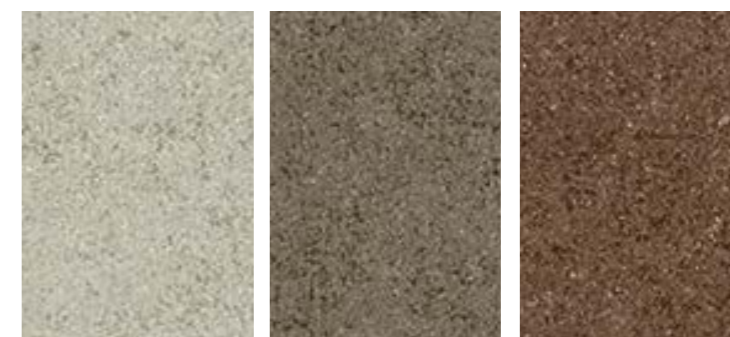

Bone

Clay

Terra

Destonified | Destonificado V.2

Available sizes & finishes.
Formatos y acabados disponibles.

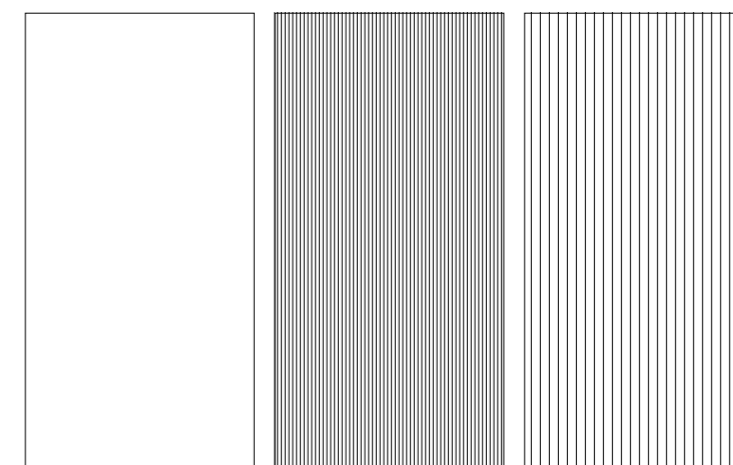

Base

60x120x0,6 cm
24"x48"

Reed

60x120x0,9 cm
24"x48"

Ribbed

60x120x0,9 cm
24"x48"

Rectified - Rectificado

Number of designs by format: | Número de diseños por formato: 60x120: 14-24

Nominal Size Formato Nominal	Real Size Formato Real	Soft Textured	Reed	Ribbed	Pice Code	Pz Box	M2 Box	Kg Box	Box Pa	M2 Pa	Kg Pa
60x120 cm. 24"x48"	59,8x119,8x0,6 cm	•			620	3	2,15	26,20	35	75,07	947
60x120 cm 24"x48"	59,8x119,8x0,9 cm		•	•	620	2	1,43	22,00	35	50,05	800



Soft Textured Finish

Anti-Slip Finish

Colours available.
Colores disponibles.

Available sizes & finishes.
Formatos y acabados disponibles.

Due

Natural brushed oak in ceramics | *Roble natural cepillado en cerámica*

Color Body Porcelain - Porcelánico Masa Coloreada

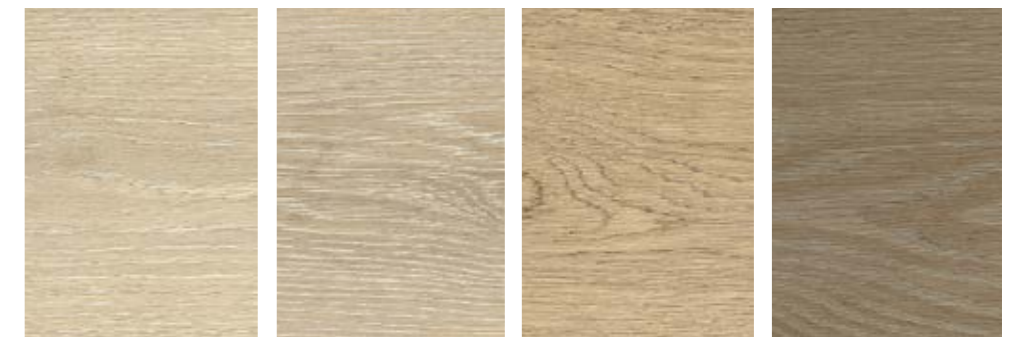

Light

Sand

Canella

Cognac



Walnut

Destonified | Destonificado V.4

20x120x0,9 cm
8"x48"

22,5x160x0,9 cm
9"x63"

22,5x200x0,9 cm
9"x79"

MOSAICS | MOSAICOS
See the available options on page 206
Consulta las opciones disponibles en la página 206

Rectified - Rectificado

Nº designs by format: | Nº de diseños por formato:
2,5x200: 32 - 22,5x160: 32 - 20x120: 33

Nominal Size Formato Nominal	Real Size Formato Real	Soft Textured C2 · R10 · CB	Anti-Slip C3 · R11	Price Code	Pz/ Box	M2/ Box	Kg/Box	Box/Pa	M2/Pa	Kg/Pa
20x120 cm. 8"x48"	19,8x119,8x0,9 cm.	•	•	20	5	1,19	25,15	45	53,55	1147
22,5x160 cm. 9"x63"	22,3x159,8x0,9 cm.	•		23	3	1,07	22,38	54	57,73	1238
22,5x200 cm. 9"x79"	22,3x199,8x0,9 cm.	•		22	3	1,34	27,97	42	56,14	1210

Colours available.
Colores disponibles.

Color Body Porcelain & Ductile 90x270 - Porcelánico Masa Coloreada & Ductile 90x270



Bone

Silver

Destonified | Destonificado V.3

Available sizes & finishes.
Formatos y acabados disponibles.

MOSAICS | MOSAICOS
See the available options on page 206
Consulta las opciones disponibles en la página 206

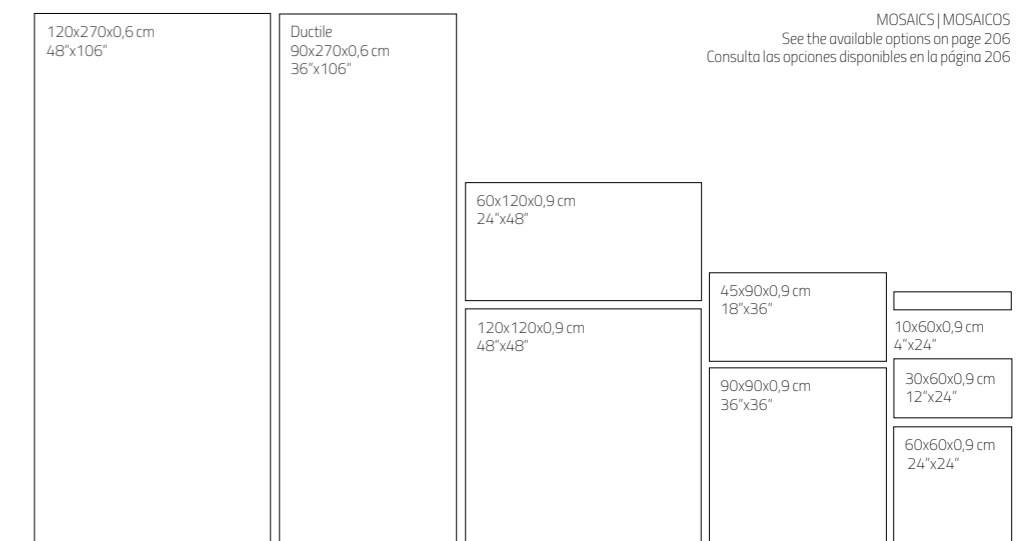

Number of designs by format: | Número de diseños por formato:
Rectified - Rectificado 120x270: 7 - 90x270: 7 - 120x120: 14 - 60x120: 14 - 90x90: 16 - 45x90: 32 - 60x60: 28 - 30x60: 56 - 10x60: 168

Nominal Size Formato Nominal	Real Size Formato Real	Natural C1 - R9 - CA	Anti-Slip C3 - R11 - CC	Price Code	Pz Box	M2 Box	Kg Box	Box Pa	M2 Pa	Kg Pa
Porcelain Tiles										
10x60 cm 4"x24"	9,8x59,8x0,9 cm	•	•	10	10	0,59	13,30	60	35,40	838
30x60 cm 12"x24"	29,8x59,8x0,9 cm	•	•	30	6	1,07	22,29	48	51,36	1110
60x60 cm 24"x24"	59,8x59,8x0,9 cm	•	•	60	3	1,07	22,45	48	51,36	1110
45x90 cm 18"x36"	44,8x89,8x0,9 cm	•	•	45	3	1,21	25,22	48	57,93	1236
90x90 cm 36"x36"	89,8x89,8x0,9 cm	•	•	90	2	1,61	33,79	30	48,30	1039
60x120 cm 24"x48"	59,8x119,8x0,9 cm	•	•	62	2	1,43	29,95	36	51,48	1110
120x120 cm 48"x48"	119,8x119,8x0,9 cm	•	•	120	1	1,44	30,11	40	57,41	1259
120x270 cm 48"x106"	119,8x269,8x0,6 cm	•		276	1	3,23	45,50	24	77,52	1222
Ductile										
90x270 cm 36"x106"	89,8x269,8x0,6 cm	•		970	1	2,42	29,04	24	58,08	801



Natural Finish

Anti-Slip Finish

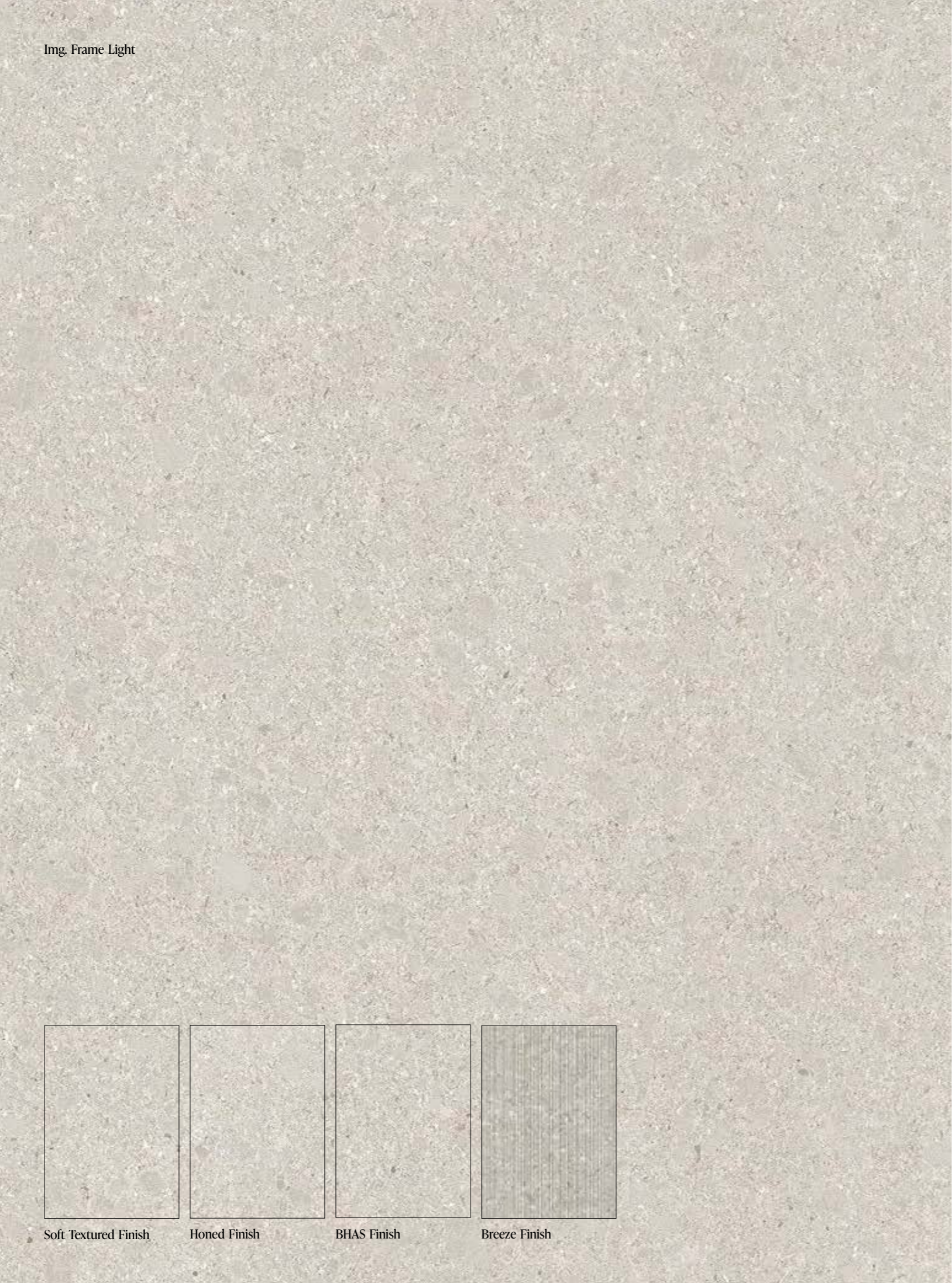

Colours available.
Colores disponibles.

Available sizes & finishes.
Formatos y acabados disponibles.

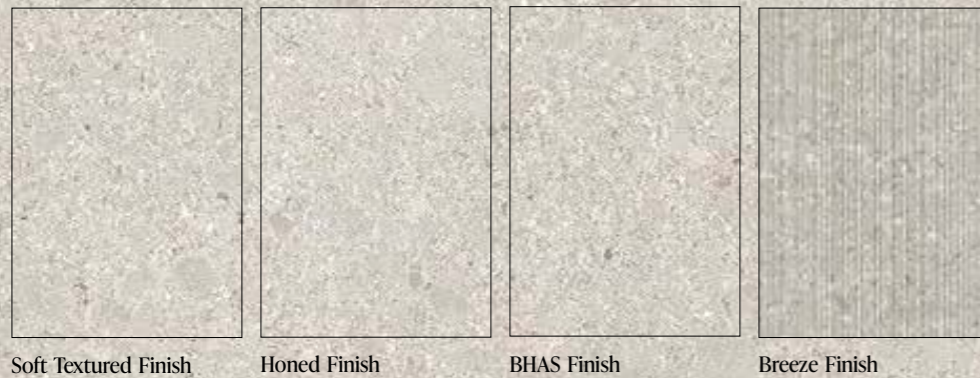

Soft Textured Finish

Honed Finish

BHAS Finish

Breeze Finish

Frame

Northern stone in ceramics | *Piedra del norte cerámica*

Color Body Porcelain & Ductile 90x270 - Porcelánico Masa Coloreada & Ductile 90x270



Ice

Light *

Classic

Destonified | Destonificado V.2

* 20mm thickness colours | Colores para 20mm

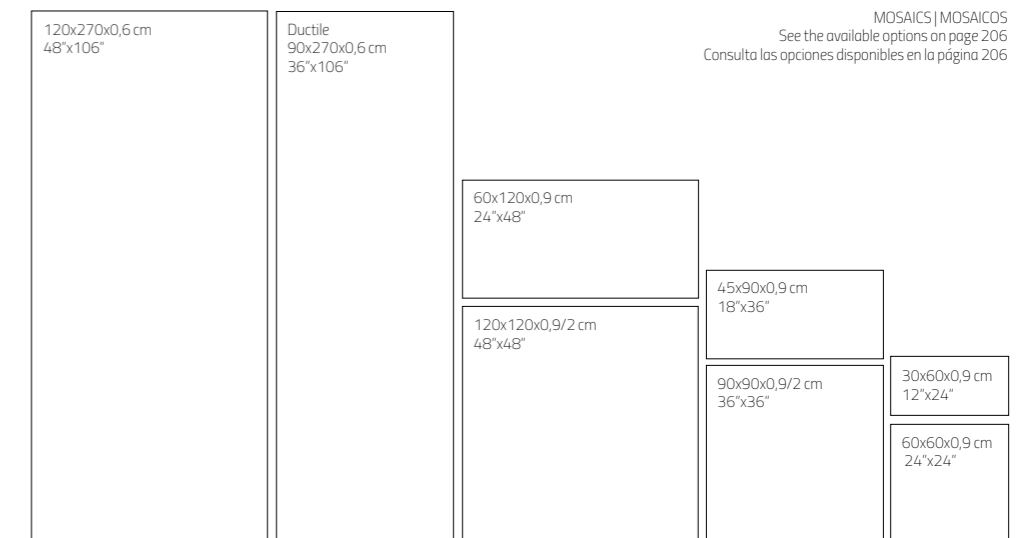

MOSAICS | MOSAICOS
See the available options on page 206
Consulta las opciones disponibles en la página 206

Rectified - Rectificado

120x270: 7 - 90x270: 7 - 120x120: 14 - 60x120: 24 - 90x90: 16 - 45x90: 32 - 60x60: 48 - 30x60: 96

Nominal Size Formato Nominal	Real Size Formato Real	Soft Textured C2-R10-CB	Honed	BHAS C3-R11-CC	Breeze	Price Code	Pz Box	M2 Box	Kg Box	Box Pa	M2 Pa	Kg Pa
Porcelain Tiles												
30x60 cm 12"x24"	29,8x59,8x0,9 cm	•	•	•		30	6	1,07	22,29	48	51,36	1110
60x60 cm 24"x24"	59,8x59,8x0,9 cm	•	•	•		60	3	1,07	22,45	48	51,36	1110
45x90 cm 18"x36"	44,8x89,8x0,9 cm	•	•	•		45	3	1,21	25,22	48	57,93	1236
90x90 cm 36"x36"	89,8x89,8x0,9 cm	•	•	•		90	2	1,61	33,79	30	48,30	1039
90x90x2 cm 36"x36"	89,8x89,8x2 cm			•		94	1	0,81	37,49	30	24,15	1170
60x120 cm 24"x48"	59,8x119,8x0,9 cm	•	•	•		62	2	1,43	29,95	36	51,48	1110
120x120 cm 48"x48"	119,8x119,8x0,9 cm	•	•	•		120	1	1,44	30,11	40	57,41	1295
120x120x2 cm 48"x48"	119,8x119,8x2 cm			•		121	1	1,44	66,02	16	22,96	1140
120x270 cm 48"x106"	119,8x269,8x0,6 cm	•	•		•	276	1	3,23	45,50	24	77,52	1222
Ductile												
90x270 cm 36"x106"	89,8x269,8x0,6 cm	•				970	1	2,42	29,04	24	58,08	801



Colours available.
Colores disponibles.

White Body - Pasta blanca

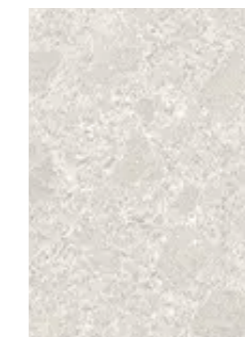

Ice



Light



Classic

Destonified | Destonificado V.2

Available sizes & finishes.
Formatos y acabados disponibles.



Base

60x120x0,6 cm
24"x48"

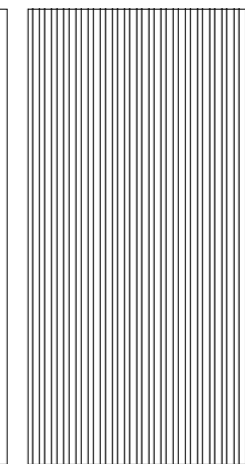

Glint

60x120x0,9 cm
24"x48"

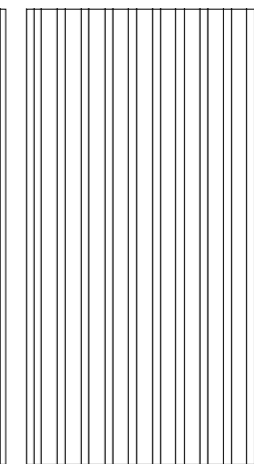

Gleam

60x120x0,9 cm
24"x48"

Rectified - Rectificado

Number of designs by format: | Número de diseños por formato: 60x120: 14-24

Nominal Size Formato Nominal	Real Size Formato Real	Soft Textured	Glint	Gleam	Pice Code	Pz Box	M2 Box	Kg Box	Box Pa	M2 Pa	Kg Pa
60x120 cm. 24"x48"	59,8x119,8x0,6 cm	•			620	3	2,15	26,20	35	75,07	947
60x120 cm 24"x48"	59,8x119,8x0,9 cm		•	•	620	2	1,43	22,00	35	50,05	800



Img. Ground Grey Tip

Img. Ground Grey Twist

Colours available.
Colores disponibles.

Available sizes & finishes.
Formatos y acabados disponibles.

White Body - Pasta blanca



Light

Cream

Grey

Destonified | Destonificado V.1

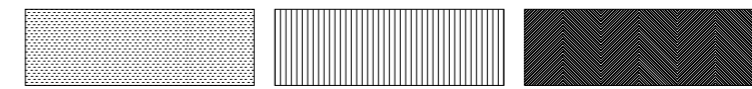

Brush

30x90x0,9 cm
12"x36"

Tip

30x90x0,9 cm
12"x36"

Twist

30x90x0,9 cm
12"x36"

Rectified - Rectificado

Number of designs by format: | Número de diseños por formato: 30x90: 16

Nominal Size Formato Nominal	Real Size Formato Real	Brush	Tip	Twist	Pice Code	Pz Box	M2 Box	Kg Box	Box Pa	M2 Pa	Kg Pa
30x90 cm 12"x36"	29,8x89,8x0,9 cm	•	•	•	320	4	1,07	17,60	54	57,78	974

Img. Gubi Ice Calm



Img. Gubi Ice Prints



Img. Gubi Ice Peak

Gubi Ductile

Microcement ceramics | *Microcemento cerámico*

Colours available.
Colores disponibles.

White Body - Pasta blanca



Ice Light Greige Cloud

Destonified | Destonificado V.2

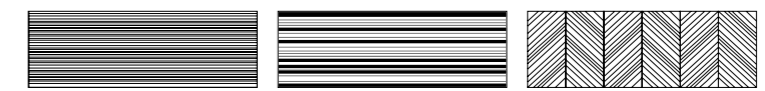

Calm Prints Peak
30x90x0,9 cm 12"x36" 30x90x0,9 cm 12"x36" 30x90x0,9 cm 12"x36"

Rectified - Rectificado

Number of designs by format: | Número de diseños por formato: 30x90: 16

Nominal Size Formato Nominal	Real Size Formato Real	Calm	Prints	Peak	Pice Code	Pz Box	M2 Box	Kg Box	Box Pa	M2 Pa	Kg Pa
30x90 cm 12"x36"	29,8x89,8x0,9 cm	•	•	•	320	4	1,07	17,60	54	57,78	974

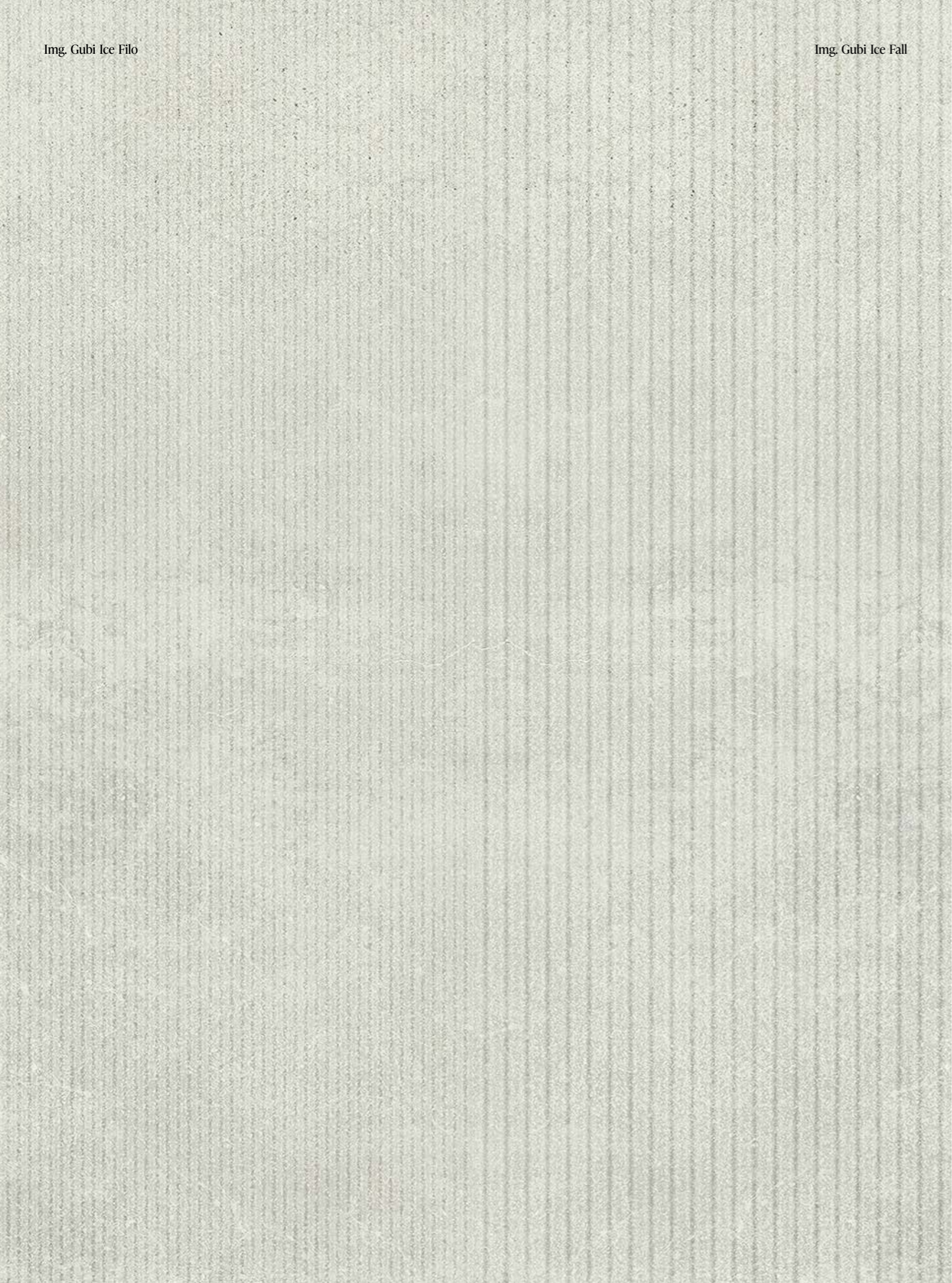

Colours available.
Colores disponibles.

White Body - Pasta blanca



Ice

Light

Greige

Cloud

Destonified | Destonificado V.2

Available sizes & finishes.
Formatos y acabados disponibles.

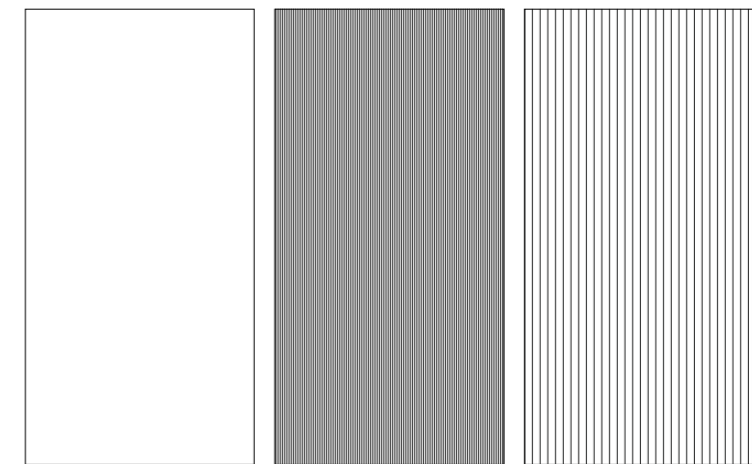

Base

60x120x0,6 cm
24"x48"

Filo

60x120x0,9 cm
24"x48"

Fall

60x120x0,9 cm
24"x48"

Rectified - Rectificado

Number of designs by format: | Número de diseños por formato: 60x120: 14-24

Nominal Size Formato Nominal	Real Size Formato Real	Natural	Soft Textured	Filo	Fall	Pice Code	Pz Box	M2 Box	Kg Box	Box Pa	M2 Pa	Kg Pa
60x120 cm. 24"x48"	59,8x119,8x0,6 cm	•	•			620	3	2,15	26,20	35	75,07	947
60x120 cm 24"x48"	59,8x119,8x0,9 cm			•	•	620	2	1,43	22,00	35	50,05	800



Soft Textured Finish

Honed Finish

BHAS Finish

Colours available.
Colores disponibles.

Available sizes & finishes.
Formatos y acabados disponibles.

Kendo

Color Body Porcelain & Ductile 90x270 - Porcelánico Masa Coloreada & Ductile 90x270



Ice

Light *

Classic *

Destonified | Destonificado V.3

* 20mm thickness colours | Colores para 20mm

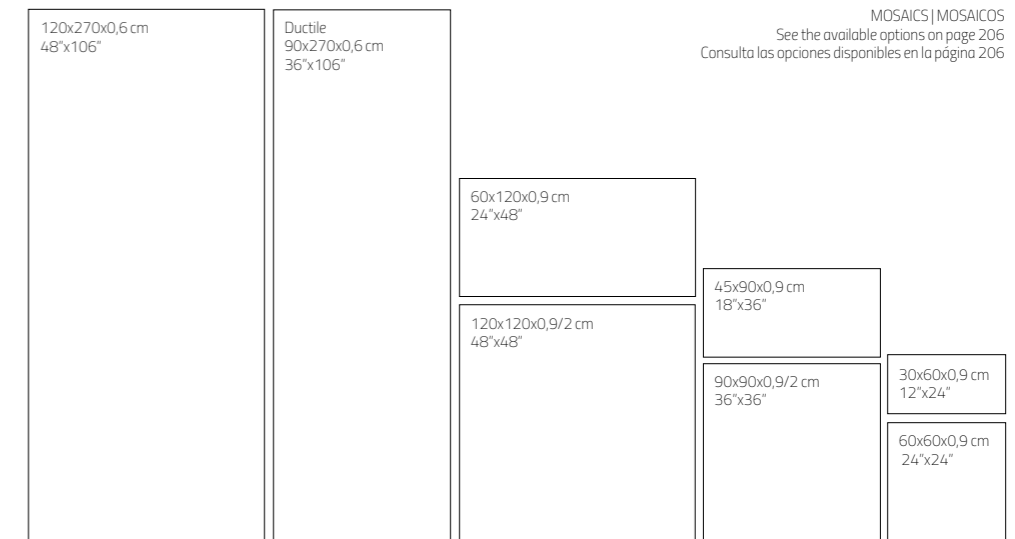

MOSAICS | MOSAICOS
See the available options on page 206
Consulta las opciones disponibles en la página 206

Rectified - Rectificado
N° Designs by format: | N° De Diseños por formato:
120x270: 7 - 90x270: 7 - 120x120: 14 - 60x120: 24 - 90x90: 16 - 45x90: 32 - 60x60: 48 - 30x60: 96

Nominal Size Formato Nominal	Real Size Formato Real	Soft Textured C2-R10 CB	Honed	BHAS C3-R11.CC	Price Code	Pz Box	M2 Box	Kg Box	Box Pa	M2 Pa	Kg Pa
Porcelain Tiles											
30x60 cm 12"x24"	29,8x59,8x0,9 cm	•	•	•	30/30H	6	1,07	22,29	48	51,36	1110
60x60 cm 24"x24"	59,8x59,8x0,9 cm	•	•	•	60/60H	3	1,07	22,45	48	51,36	1110
45x90 cm 18"x36"	44,8x89,8x0,9 cm	•	•	•	45/45H	3	1,21	25,22	48	57,93	1236
90x90 cm 36"x36"	89,8x89,8x0,9 cm	•	•	•	90/90H	2	1,61	33,79	30	48,30	1039
90x90x2 cm 36"x36"	89,8x89,8x2 cm			•	94	1	0,81	37,49	30	24,15	1170
60x120 cm 24"x48"	59,8x119,8x0,9 cm	•	•	•	62/62H	2	1,43	29,95	36	51,48	1110
120x120 cm 48"x48"	119,8x119,8x0,9 cm	•	•	•	120/120H	1	1,44	30,11	40	57,41	1259
120x120x2 cm 48"x48"	119,8x119,8x2 cm			•	121	1	1,44	66,02	16	22,96	1140
120x270 cm 48"x106"	119,8x269,8x0,6 cm	•	•		276/276H	1	3,23	45,50	24	77,52	1222
Ductile											
90x270 cm 36"x106"	89,8x269,8x0,6 cm	•			970	1	2,42	29,04	24	58,08	801



Colours available.
Colores disponibles.

Available sizes & finishes.
Formatos y acabados disponibles.

Kendo Ductile

White Body - Pasta blanca



Ice



Light



Classic

Destonified | Destonificado V.3



Base

60x120x0,6 cm
24"x48"

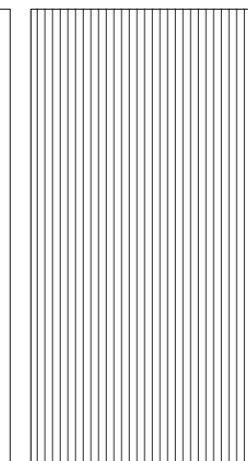

List

60x120x0,9 cm
24"x48"

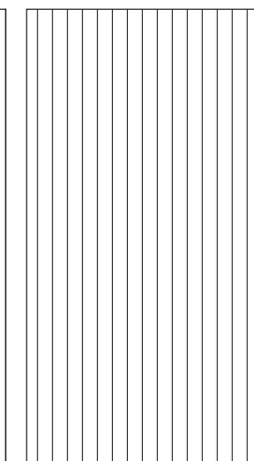

Loop

60x120x0,9 cm
24"x48"

Rectified - Rectificado

Number of designs by format: | Número de diseños por formato: 60x120: 14-24

Nominal Size Formato Nominal	Real Size Formato Real	Soft Textured	List	Loop	Pice Code	Pz Box	M2 Box	Kg Box	Box Pa	M2 Pa	Kg Pa
60x120 cm. 24"x48"	59,8x119,8x0,6 cm	•			620	3	2,15	26,20	35	75,07	947
60x120 cm 24"x48"	59,8x119,8x0,9 cm		•	•	620	2	1,43	22,00	35	50,05	800

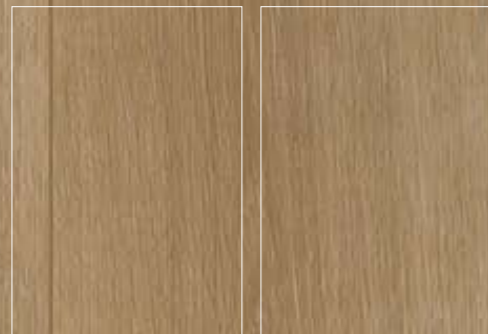
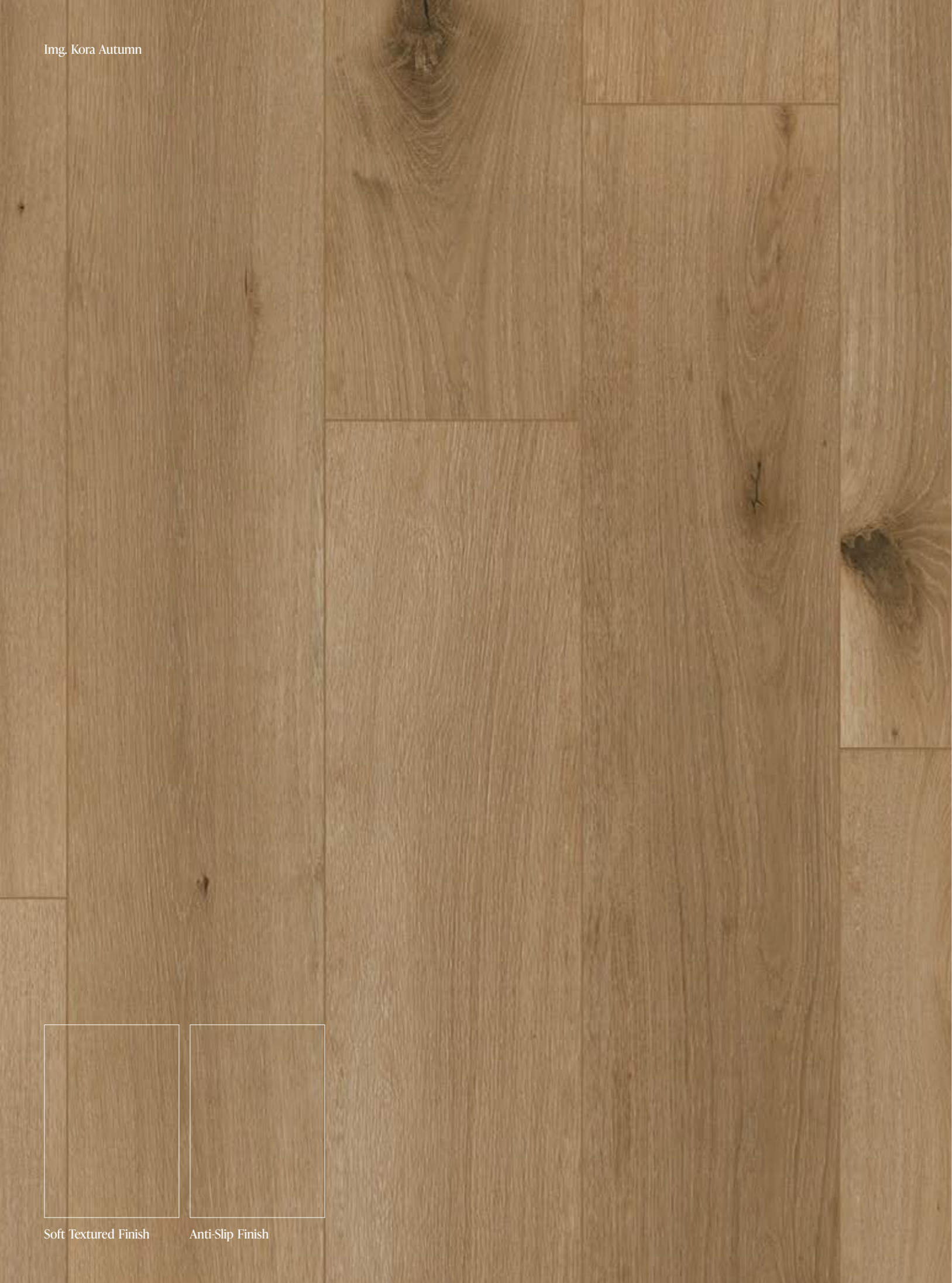

Soft Textured Finish

Anti-Slip Finish

Colours available.
Colores disponibles.

Available sizes & finishes.
Formatos y acabados disponibles.

Kora

Wildwood in ceramics | *Madera salvaje en cerámica*

Color Body Porcelain - Porcelánico Masa Coloreada

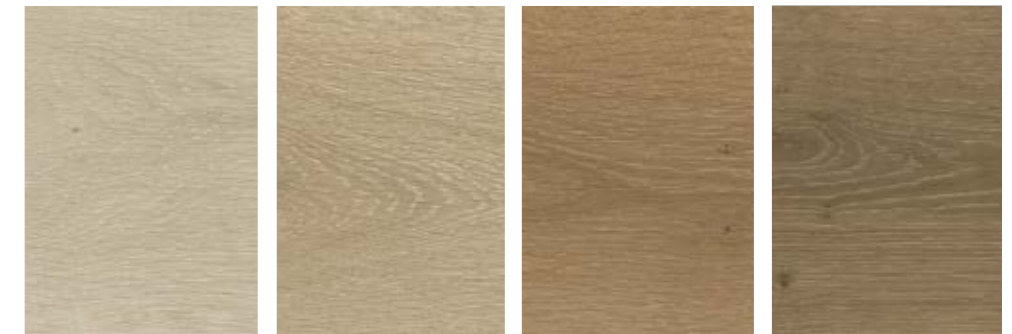

Sand

Canella

Autumn

Cognac



Walnut

Destonified | Destonificado V4

20x120x0,9 cm
8"x48"

22,5x160x0,9 cm
9"x63"

22,5x200x0,9 cm
9"x79"

MOSAICS | MOSAICOS
See the available options on page 206
Consulta las opciones disponibles en la página 206

Rectified - Rectificado

Nº designs by format: | Nº de diseños por formato:
2,5x200: 32 - 22,5x160: 32 - 20x120: 33

Nominal Size Formato Nominal	Real Size Formato Real	Soft Textured C2 · R10 · CB	Anti-Slip C3 · R11	Price Code	Pz/ Box	M2/ Box	Kg/Box	Box/Pa	M2/Pa	Kg/Pa
20x120 cm. 8"x48"	19,8x119,8x0,9 cm.	•	•	20	5	1,19	25,15	45	53,55	1147
22,5x160 cm. 9"x63"	22,3x159,8x0,9 cm.	•		23	3	1,07	22,38	54	57,73	1238
22,5x200 cm. 9"x79"	22,3x199,8x0,9 cm.	•		22	3	1,34	27,97	42	56,14	1210



Colours available.
Colores disponibles.

White Body - Pasta blanca

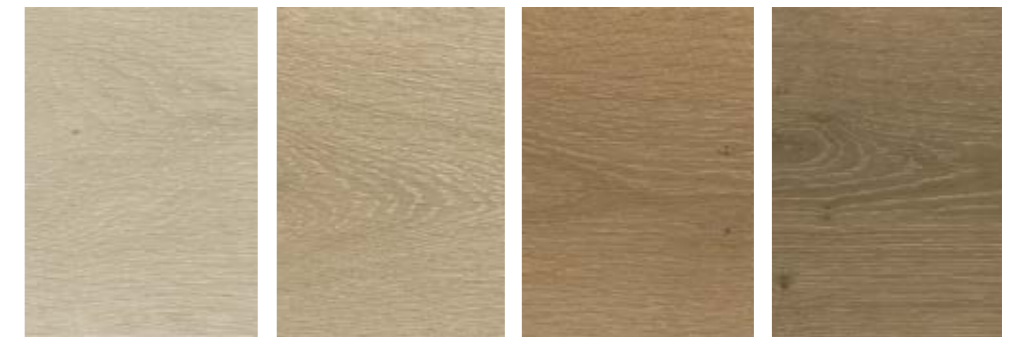

Sand

Canella

Autumn

Cognac

Destonified | Destonificado V.4

Available sizes & finishes.
Formatos y acabados disponibles.

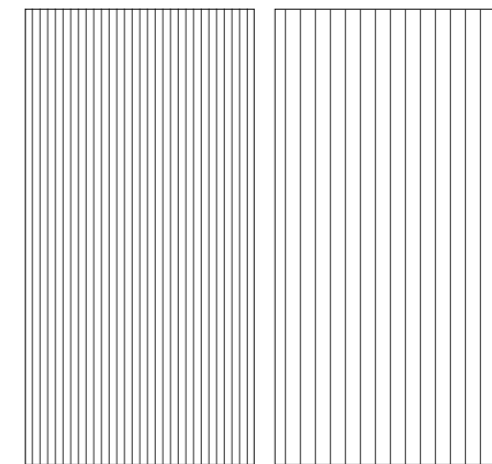

Cozy

60x120x0,9 cm
24"x48"

Cabana

60x120x1,05 cm
24"x48"

Rectified - Rectificado

Number of designs by format: | Número de diseños por formato: 60x120: 14-24

Nominal Size Formato Nominal	Real Size Formato Real	Cozy	Cabana	Pice Code	Pz Box	M2 Box	Kg Box	Box Pa	M2 Pa	Kg Pa
60x120x0,9 cm. 24"x48"	59,8x119,8x0,9 cm	•		620	2	1,43	22,00	36	51,48	824
60x120x1,05 cm. 24"x48"	59,8x119,8x1,05 cm		•	620	2	1,43	25,00	32	51,48	824

Colours available.
Colores disponibles.

Color Body Porcelain & Ductile 90x270 - Porcelánico Masa Coloreada & Ductile 90x270

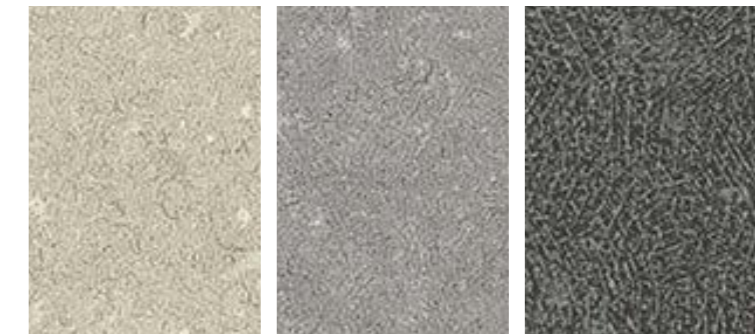

Sand *

Grey *

Anthracite

Destonified | Destonificado V.2

* 20mm thickness colours | Colores para 20mm



Available sizes & finishes.
Formatos y acabados disponibles.

MOSAICS | MOSAICOS
See the available options on page 206
Consulta las opciones disponibles en la página 206

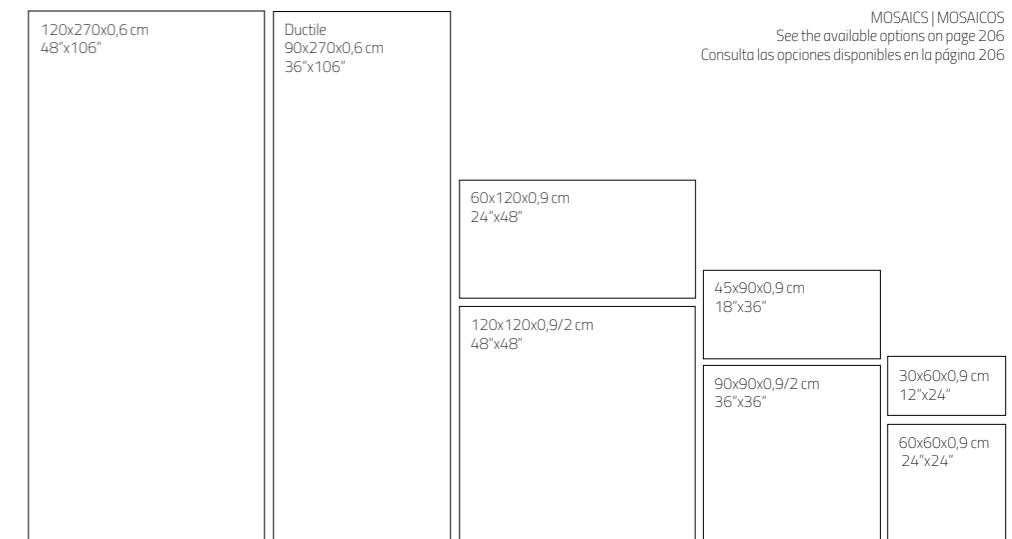

Rectified - Rectificado

120x270: 7 - 90x270: 7 - 120x120: 14 - 60x120: 24 - 90x90: 16 - 45x90: 32 - 60x60: 48 - 30x60: 96

Nominal Size Formato Nominal	Real Size Formato Real	Soft Textured C1 - R9 - CA	Anti-Slip C3 - R11 - CC	Price Code	Pz Box	M2 Box	Kg Box	Box Pa	M2 Pa	Kg Pa
Porcelain Tiles										
30x60 cm 12"x24"	29,8x59,8x0,9 cm	•	•	30	6	1,07	22,29	48	51,36	1110
60x60 cm 24"x24"	59,8x59,8x0,9 cm	•	•	60	3	1,07	22,45	48	51,36	1110
45x90 cm 18"x36"	44,8x89,8x0,9 cm	•	•	45	3	1,21	25,22	48	57,93	1236
90x90 cm 36"x36"	89,8x89,8x0,9 cm	•	•	90	2	1,61	33,79	30	48,30	1039
90x90x2 cm 36"x36"	89,8x89,8x2 cm	•	•	94	1	0,81	37,49	30	24,15	1170
60x120 cm 24"x48"	59,8x119,8x0,9 cm	•	•	62	2	1,43	29,95	36	51,48	1100
120x120 cm 48"x48"	119,8x119,8x0,9 cm	•	•	120	1	1,44	30,11	40	57,41	1259
120x120x2 cm. 48"x48"	119,8x119,8x2 cm	•	•	121	1	1,44	66,02	16	22,96	1140
120x270 cm 48"x106"	119,8x269,8x0,6 cm	•	•	276	1	3,23	45,50	24	77,52	1222
Ductile										
90x270 cm 36"x106"	89,8x269,8x0,6 cm	•	•	970	1	2,42	29,04	24	58,08	801



Soft Textured Finish

Anti-Slip Finish

Colours available.
Colores disponibles.

White Body - Pasta blanca

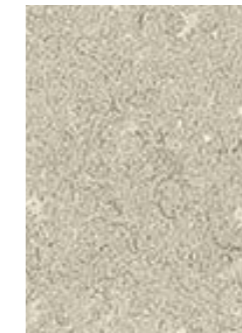

Sand

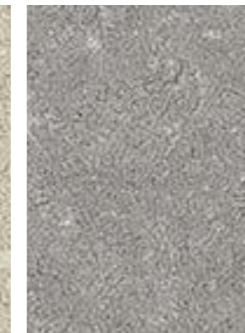

Grey

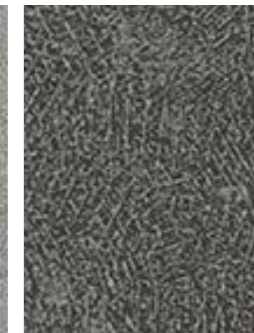

Anthracite

Destonified | Destonificado V.2

Available sizes & finishes.
Formatos y acabados disponibles.

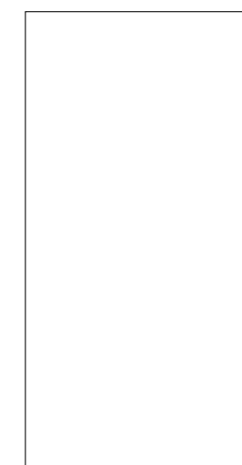

Base

60x120x0,6 cm
24"x48"

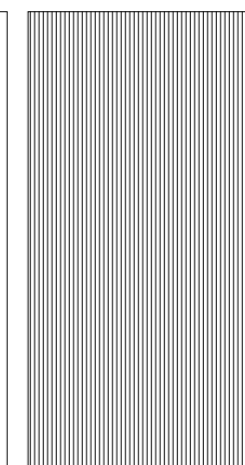

Angle

60x120x0,9 cm
24"x48"

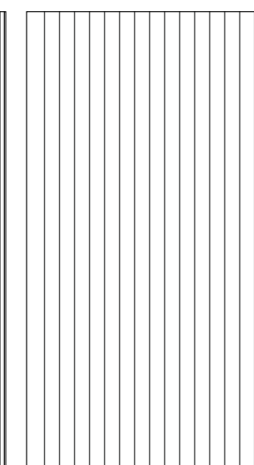

Arrow

60x120x1,05 cm
24"x48"

Rectified - Rectificado

Number of designs by format: | Número de diseños por formato: 60x120: 14-24

Nominal Size Formato Nominal	Real Size Formato Real	Soft Textured	Angle	Arrow	Pice Code	Pz Box	M2 Box	Kg Box	Box Pa	M2 Pa	Kg Pa
60x120 cm 24"x48"	59,8x119,8x0,6 cm	•			620	3	2,15	26,20	35	75,07	947
60x120 cm 24"x48"	59,8x119,8x0,9 cm		•		620	2	1,43	22,00	35	50,05	800
60x120 cm 24"x48"	59,8x119,8x1,05 cm			•	620	2	1,43	25,00	32	45,76	800



Colours available.
Colores disponibles.

Color Body Porcelain & Ductile 90x270 - Porcelánico Masa Coloreada & Ductile 90x270



Ice

Light *

Classic *

Destonified | Destonificado V.2

* 20mm thickness colours | Colores para 20mm

Available sizes & finishes.
Formatos y acabados disponibles.

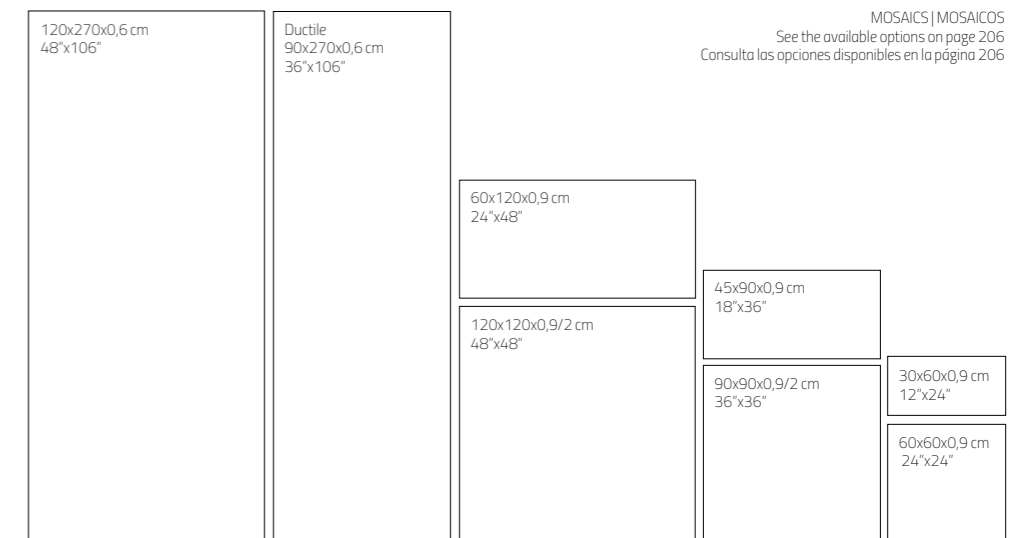

Rectified - Rectificado

Nº Designs by format | Nº De Diseños por formato:
120x270: 7 - 90x270: 7 - 120x120: 14 - 60x120: 24 - 90x90: 16 - 45x90: 32 - 60x60: 48 - 30x60: 96

Nominal Size Formato Nominal	Real Size Formato Real	Soft Textured C2-R10-CB	Honed	BHAS C3-R11-CC	Horizon	Price Code	Pz Box	M2 Box	Kg Box	Box Pa	M2 Pa	Kg Pa
Porcelain Tiles												
30x60 cm 12"x24"	29,8x59,8x0,9 cm	•	•	•		30	6	1,07	22,29	48	51,36	1110
60x60 cm 24"x24"	59,8x59,8x0,9 cm	•	•	•		60	3	1,07	22,45	48	51,36	1110
45x90 cm 18"x36"	44,8x89,8x0,9 cm	•	•	•		45	3	1,21	25,22	48	57,93	1236
90x90 cm 36"x36"	89,8x89,8x0,9 cm	•	•	•		90	2	1,61	33,79	30	48,30	1039
90x90x2 cm 36"x36"	89,8x89,8x2 cm			•		94	1	0,81	37,49	30	24,15	1170
60x120 cm 24"x48"	59,8x119,8x0,9 cm	•	•	•		62	2	1,43	29,95	36	51,48	1110
120x120 cm 48"x48"	119,8x119,8x0,9 cm	•	•	•		120	1	1,44	30,11	40	57,41	1295
120x120x2 cm 48"x48"	119,8x119,8x2 cm			•		121	1	1,44	66,02	16	22,96	1140
120x270 cm 48"x106"	119,8x269,8x0,6 cm	•	•		•	276	1	3,23	45,50	24	77,52	1222
Ductile												
90x270 cm 36"x106"	89,8x269,8x0,6 cm	•				970	1	2,42	29,04	24	58,08	801



Soft Textured Finish

Honed Finish

BHAS Finish

Horizon Finish



Colours available.
Colores disponibles.

White Body - Pasta blanca



Ice



Light



Classic

Destonified | Destonificado V.2

Available sizes & finishes.
Formatos y acabados disponibles.



Base

60x120x0,6 cm
24"x48"

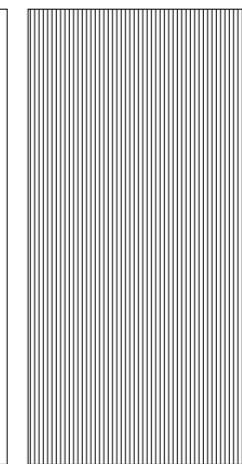

Curve

60x120x0,9 cm
24"x48"

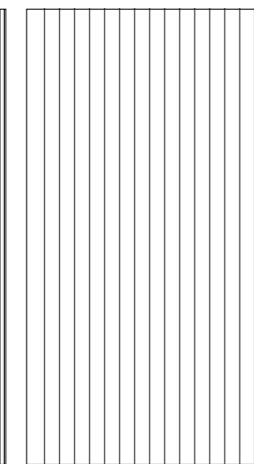

Coast

60x120x0,9 cm
24"x48"

Rectified - Rectificado

Number of designs by format: | Número de diseños por formato: 60x120: 14-24

Nominal Size Formato Nominal	Real Size Formato Real	Soft Textured	Curve	Coast	Pice Code	Pz Box	M2 Box	Kg Box	Box Pa	M2 Pa	Kg Pa
60x120 cm 24"x48"	59,8x119,8x0,6 cm	•			620	3	2,15	26,20	35	75,07	947
60x120 cm 24"x48"	59,8x119,8x0,9 cm		•	•	620	2	1,43	22,00	35	50,05	800

Img. Rem White



Soft Textured Finish

Colours available.
Colores disponibles.

Available sizes & finishes.
Formatos y acabados disponibles.

Rem

Sawn wood in ceramics | *Madera aserrada en cerámica*

Color Body Porcelain - Porcelánico Masa Coloreada



White

Soft Grey

Grey

Taupe



Black

Destonified | Destonificado V.2

5x40x0,9 cm
2"x16"

10x120x0,9 cm
4"x48"

15x120x0,9 cm
6"x48"

MOSAICS | MOSAICOS
See the available options on page 206
Consulta las opciones disponibles en la página 206

Rectified - Rectificado

N° designs by format: | N° de diseños por formato:
15x120: 112 - 10x120: 112 - 5x40: 224

Nominal Size Formato Nominal	Real Size Formato Real	Soft Textured C2 - R10 - CB	Price Code	Pz/Box	M2/Box	Kg/Box	Box/Pa	M2/Pa	Kg/Pa
5x40 cm. 2"x16"	4,8x39,8x0,9 cm.	•	6	50	0,95	19,77	50	47,5	1039
10x120 cm. 4"x48"	9,8x119,8x0,9 cm.	•	19	9	1,057	21,87	48	43,2	1088
15x120 cm. 6"x48"	14,8x119,8x0,9 cm.	•	18	6	1,064	22,02	48	51,07	1113



Soft Textured Finish

Anti-Slip Finish

Colours available.
Colores disponibles.

Available sizes & finishes.
Formatos y acabados disponibles.

Riga

Striped wood in ceramics | *Madera rayada en cerámica*

Color Body Porcelain - Porcelánico Masa Coloreada

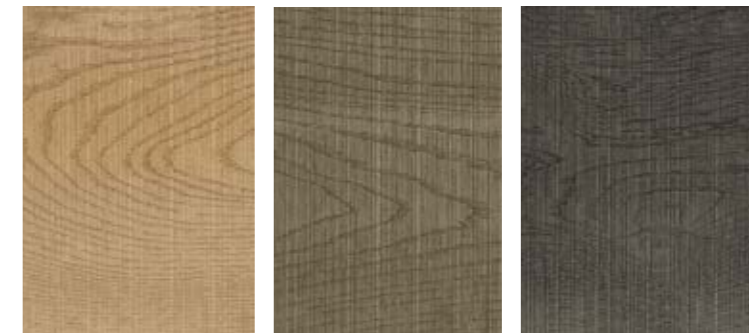

Honey

Walnut

Taupe

Destonified | Destonificado V.3

20x120x0,9 cm
8"x48"

22,5x160x0,9 cm
9"x63"

22,5x200x0,9 cm
9"x79"

MOSAICS | MOSAICOS
See the available options on page 206
Consulta las opciones disponibles en la página 206

Rectified - Rectificado

Nº designs by format: | Nº de diseños por formato:
2,5x200: 32 - 22,5x160: 32 - 20x120: 33

Nominal Size Formato Nominal	Real Size Formato Real	Soft Textured C2 · R10 · CB	Anti-Slip C3 · R11	Price Code	Pz/ Box	M2/ Box	Kg/Box	Box/Pa	M2/Pa	Kg/Pa
20x120 cm. 8"x48"	19,8x119,8x0,9 cm.	•	•	20	5	1,19	25,15	45	53,55	114,7
22,5x160 cm. 9"x63"	22,3x159,8x0,9 cm.	•		23	3	1,07	22,38	54	57,73	123,8
22,5x200 cm. 9"x79"	22,3x199,8x0,9 cm.	•		22	3	1,34	27,97	42	56,14	121,0

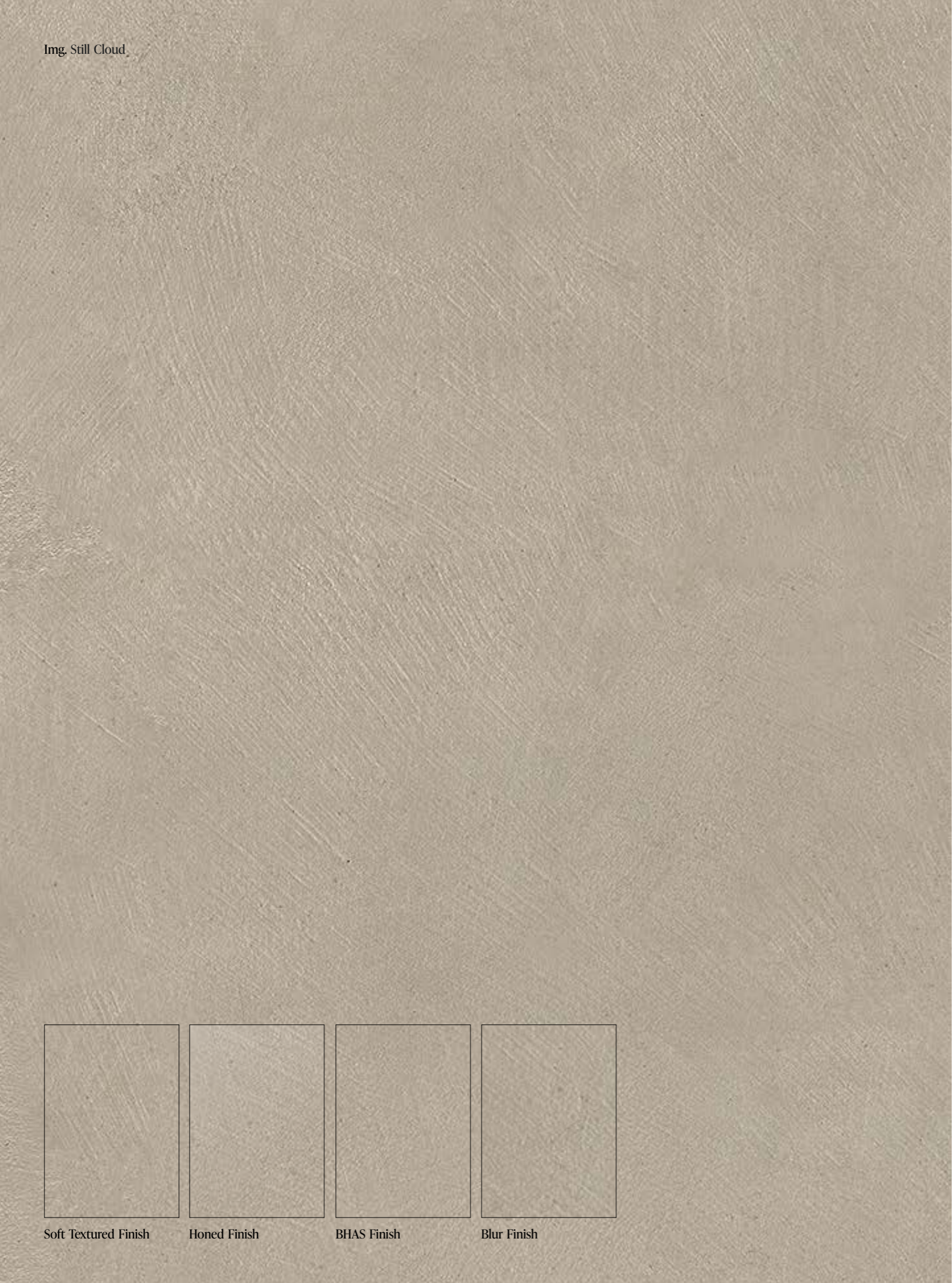

Colours available.
Colores disponibles.

Available sizes & finishes.
Formatos y acabados disponibles.



Soft Textured Finish

Honed Finish

BHAS Finish

Blur Finish

Color Body Porcelain & Ductile 90x270 - Porcelánico Masa Coloreada & Ductile 90x270



Ice

Light Grey *

Sand

Cloud *

Destonified | Destonificado V.2

* 20mm thickness colours | Colores para 20mm

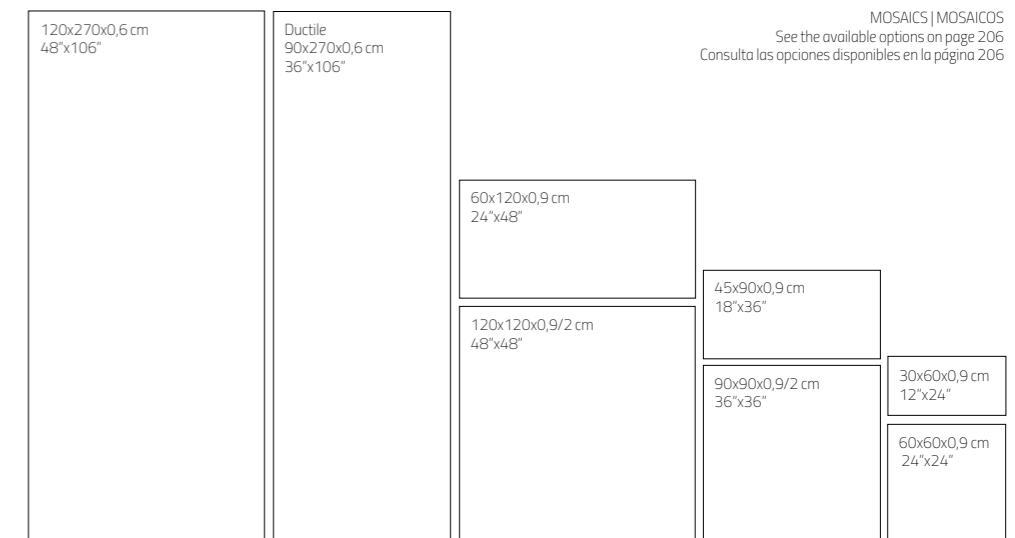

Rectified - Rectificado
Number of designs by format: | Número de diseños por formato:
120x270: 7 - 90x270: 7 - 120x120: 14 - 60x120: 14 - 90x90: 16 - 45x90: 32 - 60x60: 28 - 30x60: 56

Nominal Size Formato Nominal	Real Size Formato Real	Soft Textured C2-R10-CB	Honed	BHAS C3-R11-CC	Blur	Price Code	Pz Box	M2 Box	Kg Box	Box Pa	M2 Pa	Kg Pa
Porcelain Tiles												
30x60 cm 12"x24"	29,8x59,8x0,9 cm	•	•	•		30	6	1,07	22,29	48	51,36	1110
60x60 cm 24"x24"	59,8x59,8x0,9 cm	•	•	•		60	3	1,07	22,45	48	51,36	1110
45x90 cm 18"x36"	44,8x89,8x0,9 cm	•	•	•		45	3	1,21	25,22	48	57,93	1236
90x90 cm 36"x36"	89,8x89,8x0,9 cm	•	•	•		90	2	1,61	33,79	30	48,30	1039
90x90x2 cm 36"x36"	89,8x89,8x2 cm			•		94	1	0,81	37,49	30	24,15	1170
60x120 cm 24"x48"	59,8x119,8x0,9 cm	•	•	•		62	2	1,43	29,95	36	51,48	1110
120x120 cm 48"x48"	119,8x119,8x0,9 cm	•	•	•		120	1	1,44	30,11	40	57,41	1259
120x120x2 cm 48"x48"	119,8x119,8x2 cm			•		121	1	1,44	66,02	16	22,96	1140
120x270 cm 48"x106"	119,8x269,8x0,6 cm	•	•		•	276	1	3,23	45,50	24	77,52	1222
Ductile												
90x270 cm 36"x106"	89,8x269,8x0,6 cm	•				970	1	2,42	29,04	24	58,08	801

Colours available.
Colores disponibles.

White Body - Pasta blanca



Ice

Light Grey

Sand

Cloud

Destonified | Destonificado V.2

Available sizes & finishes.
Formatos y acabados disponibles.

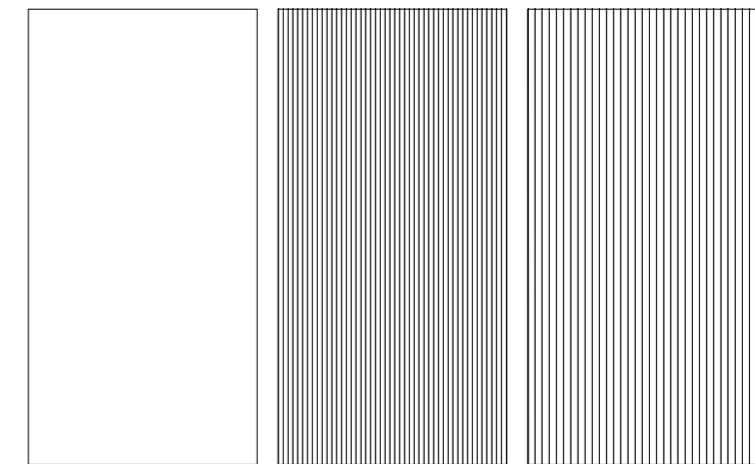

Base

60x120x0,6 cm
24"x48"

Fade

60x120x0,9 cm
24"x48"

Fold

60x120x0,9 cm
24"x48"

Rectified - Rectificado

Number of designs by format: | Número de diseños por formato: 60x120: 14-24

Nominal Size Formato Nominal	Real Size Formato Real	Soft Textured	Fade	Fold	Pice Code	Pz Box	M2 Box	Kg Box	Box Pa	M2 Pa	Kg Pa
60x120 cm. 24"x48"	59,8x119,8x0,6 cm	•			620	3	2,15	26,20	35	75,07	947
60x120 cm. 24"x48"	59,8x119,8x0,9 cm		•	•	620	2	1,43	22,00	35	50,05	800



Soft Textured Finish

Anti-Slip Finish

Colours available.
Colores disponibles.

Available sizes & finishes.
Formatos y acabados disponibles.

Uno

Color Body Porcelain - Porcelánico Masa Coloreada



Sand

Canella

Cognac

Walnut



Cocoa

Nightfall

Destonified | Destonificado V.3

20x120x0,9 cm
8"x48"

22,5x160x0,9 cm
9"x63"

22,5x200x0,9 cm
9"x79"

MOSAICS | MOSAICOS
See the available options on page 206
Consulta las opciones disponibles en la página 206

Rectified - Rectificado

Nº designs by format: | Nº de diseños por formato:
2,5x200: 32 - 22,5x160: 32 - 20x120: 33

Nominal Size Formato Nominal	Real Size Formato Real	Soft Textured C2 · R10 · CB	Anti-Slip C3 · R11	Price Code	Pz/ Box	M2/ Box	Kg/Box	Box/Pa	M2/Pa	Kg/Pa
20x120 cm. 8"x48"	19,8x119,8x0,9 cm.	•	•	20	5	1,19	25,15	45	53,55	1147
22,5x160 cm. 9"x63"	22,3x159,8x0,9 cm.	•		23	3	1,07	22,38	54	57,73	1238
22,5x200 cm. 9"x79"	22,3x199,8x0,9 cm.	•		22	3	1,34	27,97	42	56,14	1210



Colours available.
Colores disponibles.

Color Body Porcelain & Ductile 90x270 - Porcelánico Masa Coloreada & Ductile 90x270



Light *

Classic *

Grey

Destonified | Destonificada V.2

* 20mm thickness colours | Colores para 20mm

Available sizes & finishes.
Formatos y acabados disponibles.

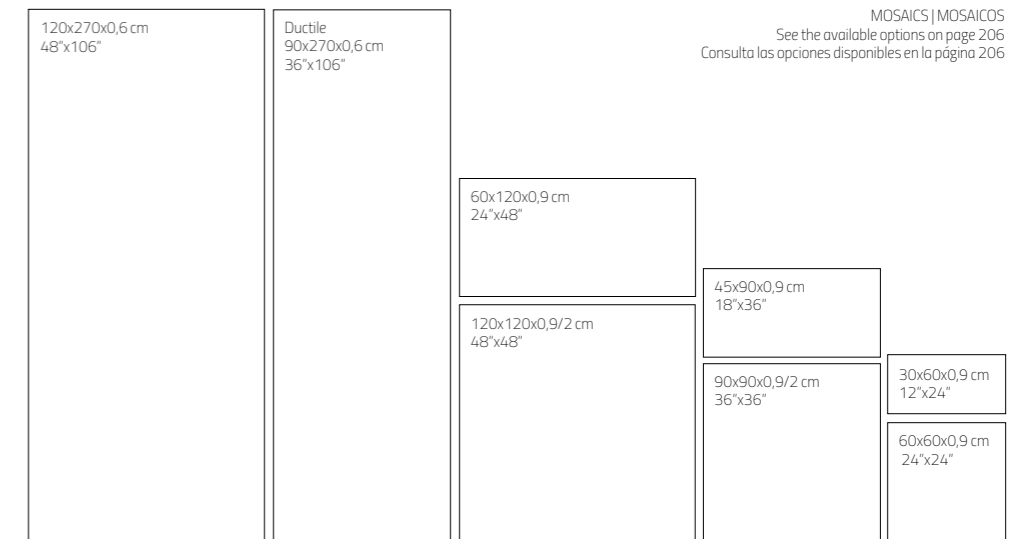

Rectified - Rectificado 120x270: 7 - 90x270: 7 - 120x120: 14 - 60x120: 24 - 90x90: 16 - 45x90: 32 - 60x60: 48 - 30x60: 96

Nominal Size Formato Nominal	Real Size Formato Real	Soft Textured C2 R10 CB	Honed	BHAS C3-R11-CC	Price Code	Pz Box	M2 Box	Kg Box	Box Pa	M2 Pa	Kg Pa
Porcelain Tiles											
30x60 cm 12"x24"	29,8x59,8x0,9 cm	•	•	•	30/30H	6	1,07	22,29	48	51,36	1110
60x60 cm 24"x24"	59,8x59,8x0,9 cm	•	•	•	60/60H	3	1,07	22,45	48	51,36	1110
45x90 cm 18"x36"	44,8x89,8x0,9 cm	•	•	•	45/45H	3	1,21	25,22	48	57,93	1236
90x90 cm 36"x36"	89,8x89,8x0,9 cm	•	•	•	90/90H	2	1,61	33,79	30	48,30	1039
90x90x2 cm 36"x36"	89,8x89,8x2 cm			•	94	1	0,81	37,49	30	24,15	1170
60x120 cm 24"x48"	59,8x119,8x0,9 cm	•	•	•	62/62H	2	1,43	29,95	36	51,48	1110
120x120 cm 48"x48"	119,8x119,8x0,9 cm	•	•	•	120/120H	1	1,44	30,11	40	57,41	1259
120x120x2 cm 48"x48"	119,8x119,8x2 cm			•	121	1	1,44	66,02	16	22,96	1140
120x270 cm 48"x106"	119,8x269,8x0,6 cm	•	•		276/276H	1	3,23	45,50	24	77,52	1222
Ductile											
90x270 cm 36"x106"	89,8x269,8x0,6 cm	•			970	1	2,42	29,04	24	58,08	801



Soft Textured Finish

Honed Finish

BHAS Finish



Colours available.
Colores disponibles.

White Body - Pasta blanca

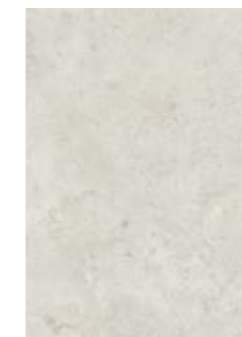

Light



Classic

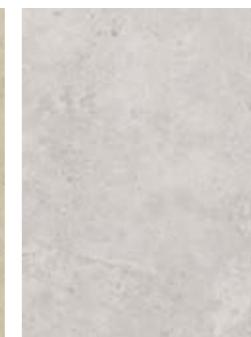

Grey

Destonified | Destonificado V.2

Available sizes & finishes.
Formatos y acabados disponibles.

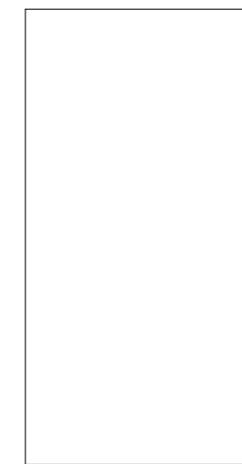

Base

60x120x0,6 cm
24"x48"

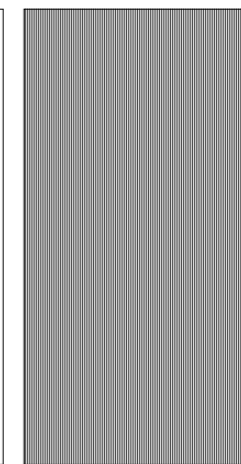

Arpa

60x120x0,9 cm
24"x48"

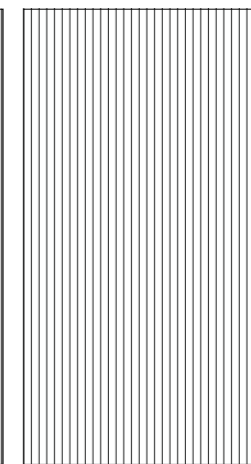

Arco

60x120x0,9 cm
24"x48"

Rectified - Rectificado

Number of designs by format: | Número de diseños por formato: 60x120: 14-24

Nominal Size Formato Nominal	Real Size Formato Real	Soft Textured	Arpa	Arco	Pice Code	Pz Box	M2 Box	Kg Box	Box Pa	M2 Pa	Kg Pa
60x120 cm. 24"x48"	59,8x119,8x0,6 cm	•			620	3	2,15	26,20	35	75,07	947
60x120 cm 24"x48"	59,8x119,8x0,9 cm		•	•	620	2	1,43	22,00	35	50,05	800



Colours available.
Colores disponibles.

Available sizes & finishes.
Formatos y acabados disponibles.

Color Body Porcelain & Ductile 90x270 - Porcelánico Masa Coloreada & Ductile 90x270



Light *

Classic *

Grey

Destonified | Destonificada V.2

* 20mm thickness colours | Colores para 20mm

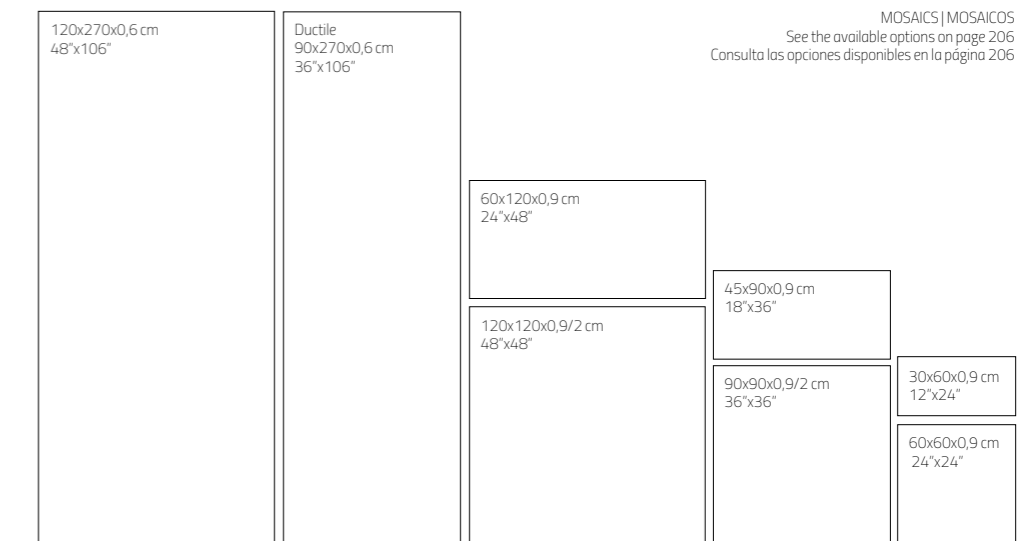

MOSAICS | MOSAICOS
See the available options on page 206
Consulta las opciones disponibles en la página 206

Rectified - Rectificado
N° Designs by format: | N° De Diseños por formato:
120x270: 7 - 90x270: 7 - 120x120: 14 - 60x120: 24 - 90x90: 16 - 45x90: 32 - 60x60: 48 - 30x60: 96



Soft Textured Finish

Honed Finish

BHAS Finish

Nominal Size Formato Nominal	Real Size Formato Real	Soft Textured C2-R10-CB	Honed	BHAS C3-R11-CC	Price Code	Pz Box	M2 Box	Kg Box	Box Pa	M2 Pa	Kg Pa
Porcelain Tiles											
30x60 cm 12"x24"	29,8x59,8x0,9 cm	•	•	•	30/30H	6	1,07	22,29	48	51,36	1110
60x60 cm 24"x24"	59,8x59,8x0,9 cm	•	•	•	60/60H	3	1,07	22,45	48	51,36	1110
45x90 cm 18"x36"	44,8x89,8x0,9 cm	•	•	•	45/45H	3	1,21	25,22	48	57,93	1236
90x90 cm 36"x36"	89,8x89,8x0,9 cm	•	•	•	90/90H	2	1,61	33,79	30	48,30	1039
90x90x2 cm 36"x36"	89,8x89,8x2 cm			•	94	1	0,81	37,49	30	24,15	1170
60x120 cm 24"x48"	59,8x119,8x0,9 cm	•	•	•	62/62H	2	1,43	29,95	36	51,48	1110
120x120 cm 48"x48"	119,8x119,8x0,9 cm	•	•	•	120/120H	1	1,44	30,11	40	57,41	1259
120x120x2 cm 48"x48"	119,8x119,8x2 cm			•	121	1	1,44	66,02	16	22,96	1140
120x270 cm 48"x106"	119,8x269,8x0,6 cm	•	•		276/276H	1	3,23	45,50	24	77,52	1222
Ductile											
90x270 cm 36"x106"	89,8x269,8x0,6 cm	•			970	1	2,42	29,04	24	58,08	801

Colours available.
Colores disponibles.

White Body - Pasta blanca



Light



Classic



Grey

Destonified | Destonificado V.2

Available sizes & finishes.
Formatos y acabados disponibles.

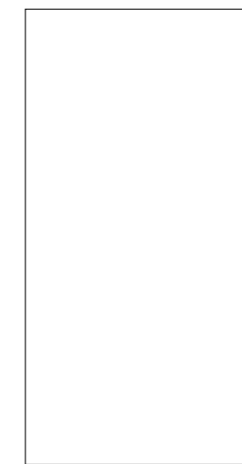

Base 60x120x0,6 cm
24"x48"

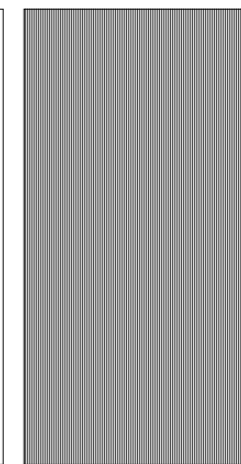

Arpa 60x120x0,9 cm
24"x48"

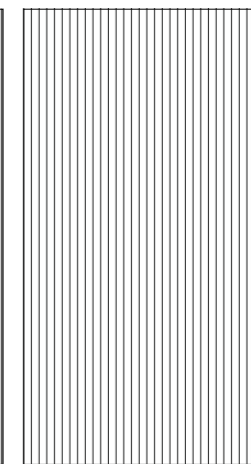

Arco 60x120x0,9 cm
24"x48"

Rectified - Rectificado

Number of designs by format: | Número de diseños por formato: 60x120: 14-24

Nominal Size Formato Nominal	Real Size Formato Real	Soft Textured	Arpa	Arco	Pice Code	Pz Box	M2 Box	Kg Box	Box Pa	M2 Pa	Kg Pa
60x120 cm 24"x48"	59,8x119,8x0,6 cm	•			620	3	2,15	26,20	35	75,07	947
60x120 cm 24"x48"	59,8x119,8x0,9 cm		•	•	620	2	1,43	22,00	35	50,05	800



Colours available.
Colores disponibles.

Available sizes & finishes.
Formatos y acabados disponibles.

Color Body Porcelain & Ductile 90x270 - Porcelánico Masa Coloreada & Ductile 90x270



Light *

Grey *

Greige

Anthracite *

Destonified | Destonificado V.3

* 20mm thickness colours | Colores para 20mm

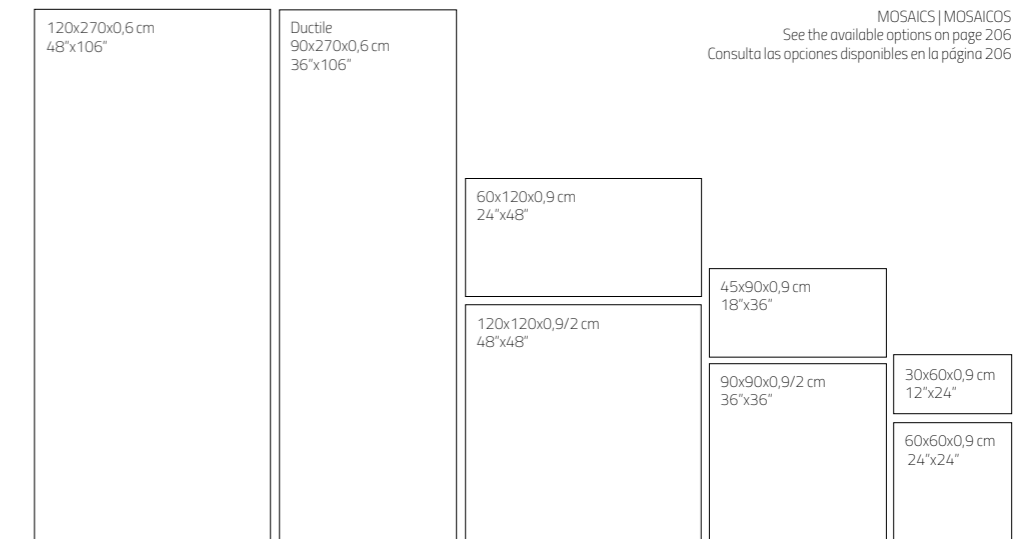

MOSAICS | MOSAICOS
See the available options on page 206
Consulta las opciones disponibles en la página 206

Rectified - Rectificado 120x270: 7 - 90x270: 7 - 120x120: 14 - 60x120: 24 - 90x90: 16 - 45x90: 32 - 60x60: 48 - 30x60: 96

Nominal Size Formato Nominal	Real Size Formato Real	Soft Textured C2 R10 CB	Honed	BHAS C3 R11 CC	Price Code	Pz Box	M2 Box	Kg Box	Box Pa	M2 Pa	Kg Pa
Porcelain Tiles											
30x60 cm 12"x24"	29,8x59,8x0,9 cm	•	•	•	30/30H	6	1,07	22,29	48	51,36	1110
60x60 cm 24"x24"	59,8x59,8x0,9 cm	•	•	•	60/60H	3	1,07	22,45	48	51,36	1110
45x90 cm 18"x36"	44,8x89,8x0,9 cm	•	•	•	45/45H	3	1,21	25,22	48	57,93	1236
90x90 cm 36"x36"	89,8x89,8x0,9 cm	•	•	•	90/90H	2	1,61	33,79	30	48,30	1039
90x90x2 cm 36"x36"	89,8x89,8x2 cm			•	94	1	0,81	37,49	30	24,15	1170
60x120 cm 24"x48"	59,8x119,8x0,9 cm	•	•	•	62/62H	2	1,43	29,95	36	51,48	1110
120x120 cm 48"x48"	119,8x119,8x0,9 cm	•	•	•	120/120H	1	1,44	30,11	40	57,41	1259
120x120x2 cm 48"x48"	119,8x119,8x2 cm			•	121	1	1,44	66,02	16	22,96	1140
120x270 cm 48"x106"	119,8x269,8x0,6 cm	•	•		276/276H	1	3,23	45,50	24	77,52	1222
Ductile											
90x270 cm 36"x106"	89,8x269,8x0,6 cm	•			970	1	2,42	29,04	24	58,08	801



Soft Textured Finish

Honed Finish

BHAS Finish



Colours available.
Colores disponibles.

White Body - Pasta blanca



Light



Grey



Greige

Destonified | Destonificado V.3

Available sizes & finishes.
Formatos y acabados disponibles.



Base

60x120x0,6 cm
24"x48"

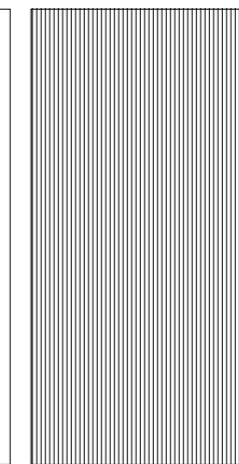

Loom

60x120x0,9 cm
24"x48"

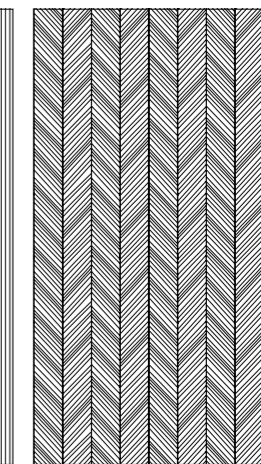

Leaf

60x120x0,9 cm
24"x48"

Rectified - Rectificado

Number of designs by format: | Número de diseños por formato: 60x120: 14-24

Nominal Size Formato Nominal	Real Size Formato Real	Soft Textured	Loom	Leaf	Pice Code	Pz Box	M2 Box	Kg Box	Box Pa	M2 Pa	Kg Pa
60x120 cm 24"x48"	59,8x119,8x0,6 cm	•			620	3	2,15	26,20	35	75,07	947
60x120 cm 24"x48"	59,8x119,8x0,9 cm		•	•	620	2	1,43	22,00	35	50,05	800



Soft Textured Finish

Colours available.
Colores disponibles.

Available sizes & finishes.
Formatos y acabados disponibles.

Through-body porcelain - Porcelánico técnico todo masa



Grey

Destonified | Destonificado V.2

EN

The full body porcelain tile delivers certain advantages vs other collections, without losing all benefits the glaze porcelain offers, its main feature resides in its inside. The raw material that shapes the tile become uniform without any superficial decoration that delivers the same aesthetic throughout the tile, this particularity make it the best fit for all those spaces that demand the most hard wearing materials.

ES

La cerámica técnica de alto rendimiento confiere ciertas ventajas con respecto a otras colecciones. Sin dejar de ofrecer todos los beneficios de un Gres Porcelánico, su característica más evidente se encuentra en su interior. La masa cerámica que conforma la pieza pasa a ser uniforme y deja de utilizarse una decoración superficial, para conferir a toda la pieza el mismo aspecto, incluyendo laterales e interior. Esta particularidad lo hace idóneo para revestir espacios con alto tráfico peatonal sometidos a un gran desgaste y que necesiten de un pavimento que ofrezca las más altas garantías superficiales.

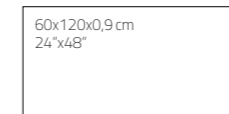

Rectified - Rectificado

Unlimited numbers of designs by format.
Número de diseños por formato ilimitado.

Nominal Size Formato Nominal	Real Size Formato Real	Soft Textured R10 CB	Price Code	Pz Box	M2 Box	Kg Box	Box Pa	M2 Pa	Kg Pa
60x120 cm 24"x48"	59,8x119,8x0,9 cm	•	62T	2	1,43	29,95	36	51,48	1110
120x120 cm 48"x48"	119,8x119,8x0,9 cm	•	120T	1	1,44	30,11	40	57,41	1259

Colours available.
Colores disponibles.

Through-body porcelain - Porcelánico técnico todo masa



EN.
The full body porcelain tile delivers certain advantages vs other collections, without losing all benefits the glaze porcelain offers, its main feature resides in its inside. The raw material that shapes the tile become uniform without any superficial decoration that delivers the same aesthetic throughout the tile, this particularity make it the best fit for all those spaces that demand the most hard wearing materials.

ES.
La cerámica técnica de alto rendimiento confiere ciertas ventajas con respecto a otras colecciones. Sin dejar de ofrecer todos los beneficios de un Gres Porcelánico, su característica más evidente se encuentra en su interior. La masa cerámica que conforma la pieza pasa a ser uniforme y deja de utilizarse una decoración superficial, para conferir a toda la pieza el mismo aspecto, incluyendo laterales e interior. Esta particularidad la hace idóneo para revestir espacios con alto tráfico peatonal sometidos a un gran desgaste y que necesiten de un pavimento que ofrezca las más altas garantías superficiales.

Black

Destonified | Destonificado V.2

Available sizes & finishes.
Formatos y acabados disponibles.

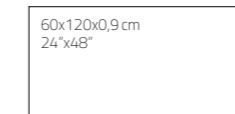
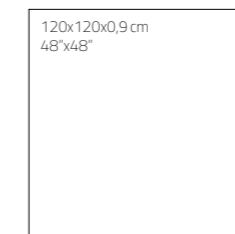

Rectified - Rectificado
Unlimited numbers of designs by format.
Número de diseños por formato ilimitado.

Nominal Size Formato Nominal	Real Size Formato Real	Soft Textured R10 CB	Price Code	Pz Box	M2 Box	Kg Box	Box Pa	M2 Pa	Kg Pa
60x120 cm 24"x48"	59,8x119,8x0,9 cm	•	62T	2	1,43	29,95	36	51,48	1110
120x120 cm 48"x48"	119,8x119,8x0,9 cm	•	120T	1	1,44	30,11	40	57,41	1259



Soft Textured Finish



SIGNATURE SURFACES

[02]

EN.

Signature Surfaces emerges as an inspiring synergy between creative minds and our ceramic universe. It isn't born—it is revealed: like a natural gesture, the extension of a shared vision.

The result of collaborations with renowned designers, each piece embodies a unique interpretation of ceramics. These are original creations, with textures and finishes that evoke emotion and give each space its own distinct identity. Because in every shape, in every nuance, our way of understanding design is expressed.

ES.

Signature Surfaces surge como una inspiradora sinergia entre mentes creativas y nuestro universo cerámico. No nace, se revela: como un gesto natural, como la prolongación de una visión compartida.

Fruto de colaboraciones con reconocidos diseñadores, cada pieza encarna una interpretación única de la cerámica. El resultado son creaciones inéditas, con texturas y acabados que despiertan emociones y dotan a cada espacio de una identidad propia. Porque en cada forma, en cada matiz, se expresa nuestra manera de entender el diseño.



A dialogue between visionary minds and creators—
a meeting point where artistic vision converges with ceramic innovation.



The geometry of light

BALANCE



[Col.]

Víctor Carrasco

EN.

Balance is a quiet geometry of light. Each piece in the collection—singular, crystalline, and precise—acts like a prism, reflecting more than design: is an expression of intention. These fragments, when brought together, create a rhythm of glows and silences, as if light were composing its own choreography across space.

The collection evokes a sense of presence that doesn't need to shout. This is not a traditional surface—it is a composition born of clarity, of a desire to create harmony without losing soul. Balance is intention, beauty, and quiet transformation.

From Valencia, Víctor Carrasco draws a subtle line between sensitivity and strategy. An Industrial Design Engineer with a vision that transcends trends, he has devoted his career to shaping brands and objects with soul.

As Founder and Strategic Director of Viccarbe, his work resides at the intersection of thoughtful business vision and quiet elegance. His approach is clear: to reduce until only the essential remains, to build from calm, and to design toward the future without losing authenticity.

ES.

Balance es una geometría sutil que nace de la luz. Cada pieza—singular, precisa, cristalina—actúa como un pequeño prisma que refleja más que diseño: es un acto de intención. Un conjunto de fragmentos que, juntos, componen una coreografía de destellos y pausas, como la luz danzando con el espacio al amanecer.

La colección evoca una presencia que no necesita imponerse. No es una superficie convencional, sino una composición que nace de la claridad, del deseo de crear armonía sin perder el alma. Balance no es simetría; es intención, belleza y transformación llamada.

Desde Valencia, Víctor Carrasco traza una línea sutil entre la sensibilidad y la estrategia. Ingeniero en Diseño Industrial, con una mirada que va más allá de las tendencias, ha dedicado su trayectoria a dar forma a marcas y objetos con alma.

Como Fundador y Director Estratégico de Viccarbe, su trabajo habita el punto exacto donde se encuentran la visión empresarial y la elegancia llamada. Su enfoque es claro: reducir hasta encontrar lo esencial, construir desde la calma, proyectar hacia el futuro sin perder autenticidad.



Colours available.
Colores disponibles.

Available sizes & finishes.
Formatos y acabados disponibles.

BALANCE

Color Body Porcelain - Porcelánico Masa Coloreada



Moon White

Clay

Olive

Pavillion Grey



Basalt

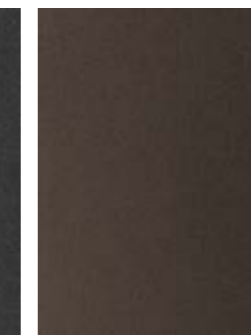

Silt



Ocean

Destonified | Destonificado V.4

5x30 cm
2"x12"

5x15 cm
2"x6"

10x10 cm
4"x4"

Rectified - Rectificado

Number of designs by format: | Número de diseños por formato:
5x15: 56 - 5x30: 28 - 10x10: 55

Nominal Size Formato Nominal	Real Size Formato Real	Price Code	Pz/Box	M2/Box	Kg/Box	Box/Pa	M2/Pa	Kg/Pa
5x15 cm. 2"x6"	4,8x14,8x0,9 cm	50-1	60	0,43	9,60	60	25,80	580
5x30 cm. 2"x12"	4,8x29,8x0,9 cm	50-2	30	0,43	9,60	60	25,80	580
10x10 cm. 4"x4"	9,8x9,8x0,9 cm	50-3	45	0,43	9,60	60	25,80	580

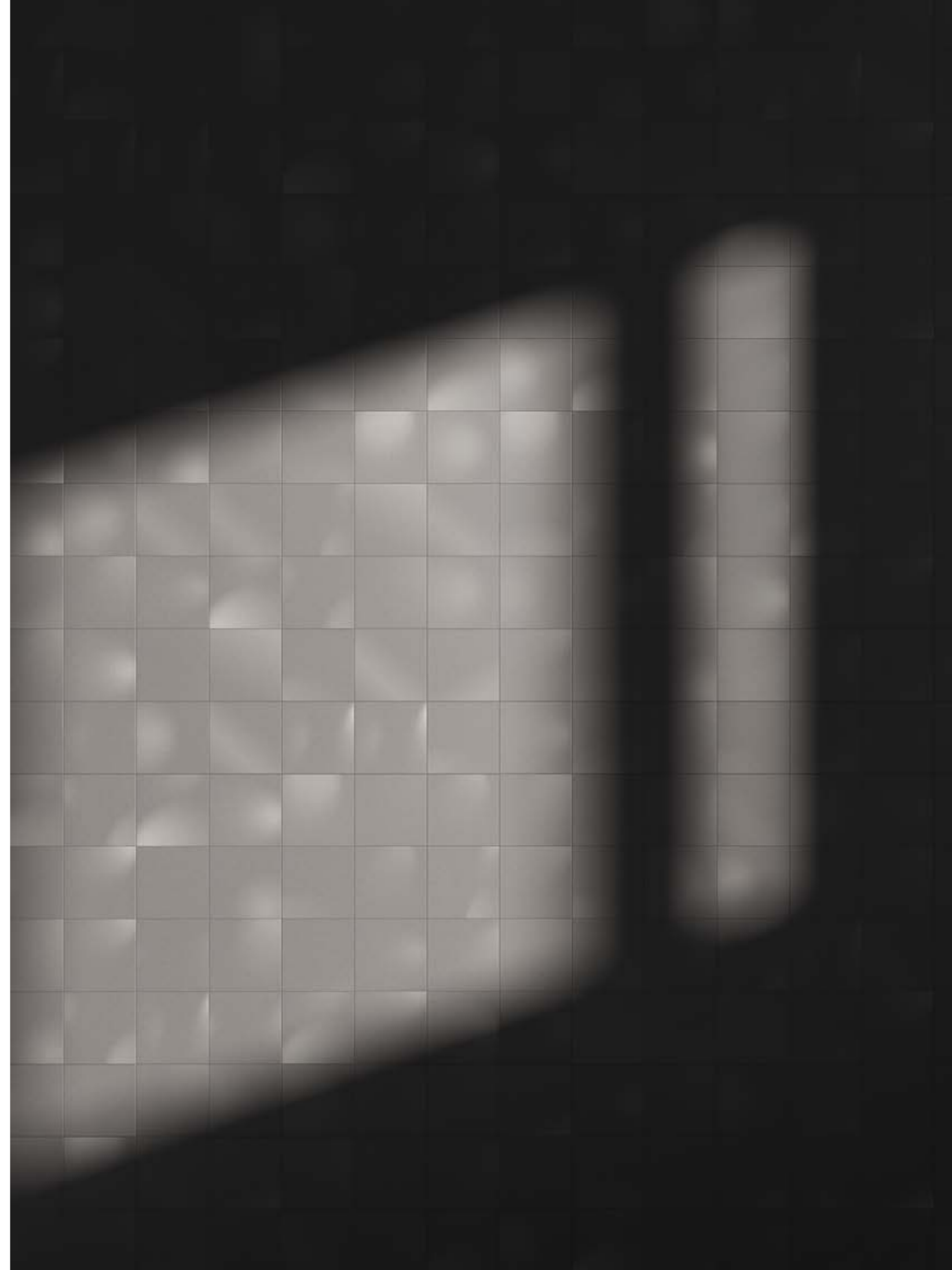
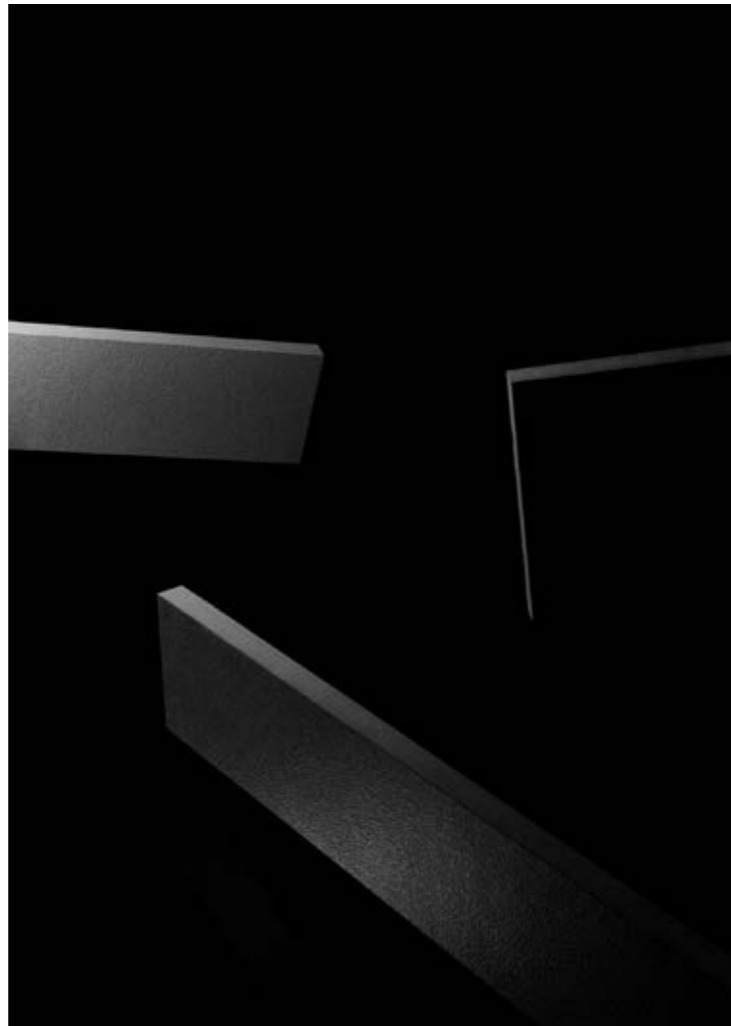



The shape between

CAVA



[Col.]

LucidiPevere

EN

Like birds in flight crossing an open sky, Cava traces geometry in motion. There is no imposed order—only a rhythm that emerges from the path: lines that intersect, spaces that unfold, fragments falling into unexpected harmony. This collection is not defined by what it shows, but by what it reveals. Between incision and surface, colour and emptiness, a new form begins to take shape. Decoration becomes structure. Absence becomes meaning.

Paolo Lucidi and Luca Pevere founded their studio in 2006 with a clear belief: that beauty lies not in the extraordinary, but in how we see the everyday. Trained in Milan and shaped by years of collaboration with iconic Italian design firms, they create pieces that transform function into gesture, and structure into emotion.

Their work begins with precise observation, a desire to give new expressiveness to what is essential. With a sober, rigorous aesthetic deeply rooted in materiality, they have collaborated with some of the most influential brands in contemporary design. Their creations live in balance: between clarity and surprise, between geometry and rhythm.

ES

Como aves en vuelo cruzando el cielo, Cava traza geometrías en movimiento. No hay un orden impuesto, pero sí un ritmo que emerge del trayecto: líneas que se cruzan, espacios que se abren, fragmentos que encajan en una armonía inesperada. La colección no se entiende por lo que muestra, sino por lo que revela. Entre la incisión y la superficie, entre el color y el vacío, nace una forma nueva. Lo decorativo se vuelve estructural; la ausencia, protagonista.

Paolo Lucidi y Luca Pevere fundaron su estudio en 2006 con una convicción clara: la belleza no está en lo extraordinario, sino en la forma de mirar lo cotidiano. Formados en Milán, y con una sólida experiencia junto a grandes nombres del diseño italiano, desarrollan piezas que transforman lo funcional en gesto, y lo estructural en emoción.

Su trabajo parte de la observación precisa, del deseo de dotar a lo esencial de una nueva expresividad. Con una estética sobria, rigurosa y profundamente ligada a la materia, han colaborado con algunas de las marcas más influyentes del diseño contemporáneo. Sus creaciones habitan el equilibrio: entre lo claro y lo inesperado, entre la geometría y el ritmo.



Colours available.
Colores disponibles.

Available sizes & finishes.
Formatos y acabados disponibles.

CAVA

A collection by LucidiPevere

Color Body Porcelain - Porcelánico Masa Coloreada



White

Beige

Grey

Brown



Green



Black



Destonified | Destonificado V.2

The joint color is yours to choose. This is just a starting point.
El color de la junta queda a tu elección. Esto es solo un punto de partida.

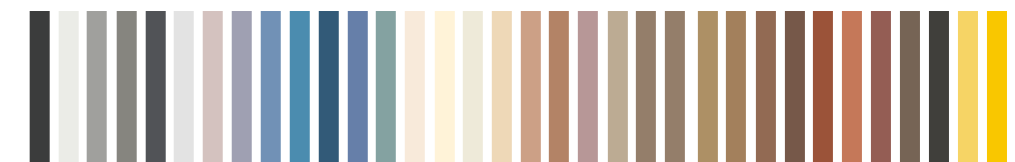

Rectified - Rectificado

Nominal Size Formato Nominal	Real Size Formato Real	Price Code	Pz/Box	M2/Box	Kg/Box	Box/Pa	M2/Pa	Kg/Pa
13x15 cm 5"x6"	12,6x14,6x0,9 cm	11	24	0,33	8,40	60	19,96	540
7,5x30 cm 3"x12"	7,3x29,8x0,9 cm	12	24	0,52	11,52	60	31,33	703
15x30 cm 6"x12"	14,8x29,8x0,9 cm	13	12	0,53	11,76	60	31,75	742
10x60 cm 4"x24"	9,8x59,8x0,9 cm	14	10	0,59	13,30	60	35,40	837
30x60 cm 12"x24"	29,8x59,8x0,9 cm	30	6	1,07	22,00	48	51,36	1094
60x60 cm 24"x24"	59,8x59,8x0,9 cm	60	3	1,07	23,22	48	51,36	1094
45x90 cm 18"x36"	44,8x89,8x0,9 cm	45	3	1,21	25,50	48	58,08	1237
90x90 cm 36"x36"	89,8x89,8x0,9 cm	90	2	1,61	34,00	30	48,30	1057
Cava Mosaic A	22,8x27,8x0,9 cm	20-1	5	0,31	9,00	60	19,02	565
Cava Mosaic B	27,5x29,6x0,9 cm	20-2	5	0,40	9,00	60	24,42	565
Cava Mosaic C	29,5x29,9x0,9 cm	20-3	5	0,44	9,00	60	26,46	565
Cava Mosaic D	22,8x27,1x0,9 cm	20-4	5	0,30	9,00	60	18,54	565
Cava Mosaic E	22,8x27,8x0,9 cm	20-5	5	0,31	9,00	60	19,02	565



Img. Cava, Beige 90B & Green 7C



Img. Cava, White 13A

	Base	Pattern 1	Pattern 2	Pattern 3
13 - Patterns	13	13 A	13 B	13 C
Nominal Size Formato Nominal / Real Size Formato Real 13x15 cm 5"x6" / 12,6x14,6x0,9 cm				
7 - Patterns	7	7 A	7 B	7 C
Nominal Size Formato Nominal / Real Size Formato Real 7,5x30 cm 3"x12" / 7,3x29,8x0,9 cm				
15 - Patterns	15	15 A	15 B	15 C
Nominal Size Formato Nominal / Real Size Formato Real 15x30 cm 6"x12" / 14,8x29,8x0,9 cm				
10 - Patterns	10	10 A	10 B	10 C
Nominal Size Formato Nominal / Real Size Formato Real 10x60 cm 4"x24" / 9,8x59,8x0,9 cm				
30 - Patterns	30	30 A	30 B	30 C
Nominal Size Formato Nominal / Real Size Formato Real 30x60 cm 12"x24" / 29,8x59,8x0,9 cm				
60 - Patterns	60	60 A	60 B	60 C
Nominal Size Formato Nominal / Real Size Formato Real 60x60 cm 24"x24" / 59,8x59,8x0,9 cm				
45 - Patterns	45	45 A	45 B	45 C
Nominal Size Formato Nominal / Real Size Formato Real 60x60 cm 24"x24" / 59,8x59,8x0,9 cm				
90 - Patterns	90	90 A	90 B	90 C
Nominal Size Formato Nominal / Real Size Formato Real 90x90 cm 36"x36" / 89,8x89,8x0,9 cm				

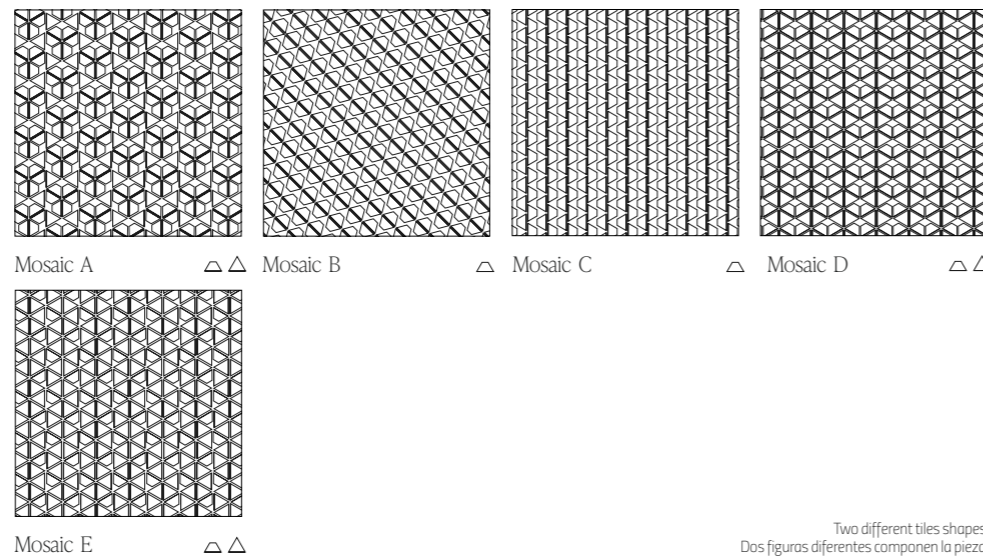

Two different tiles shapes
Dos figuras diferentes componen la pieza

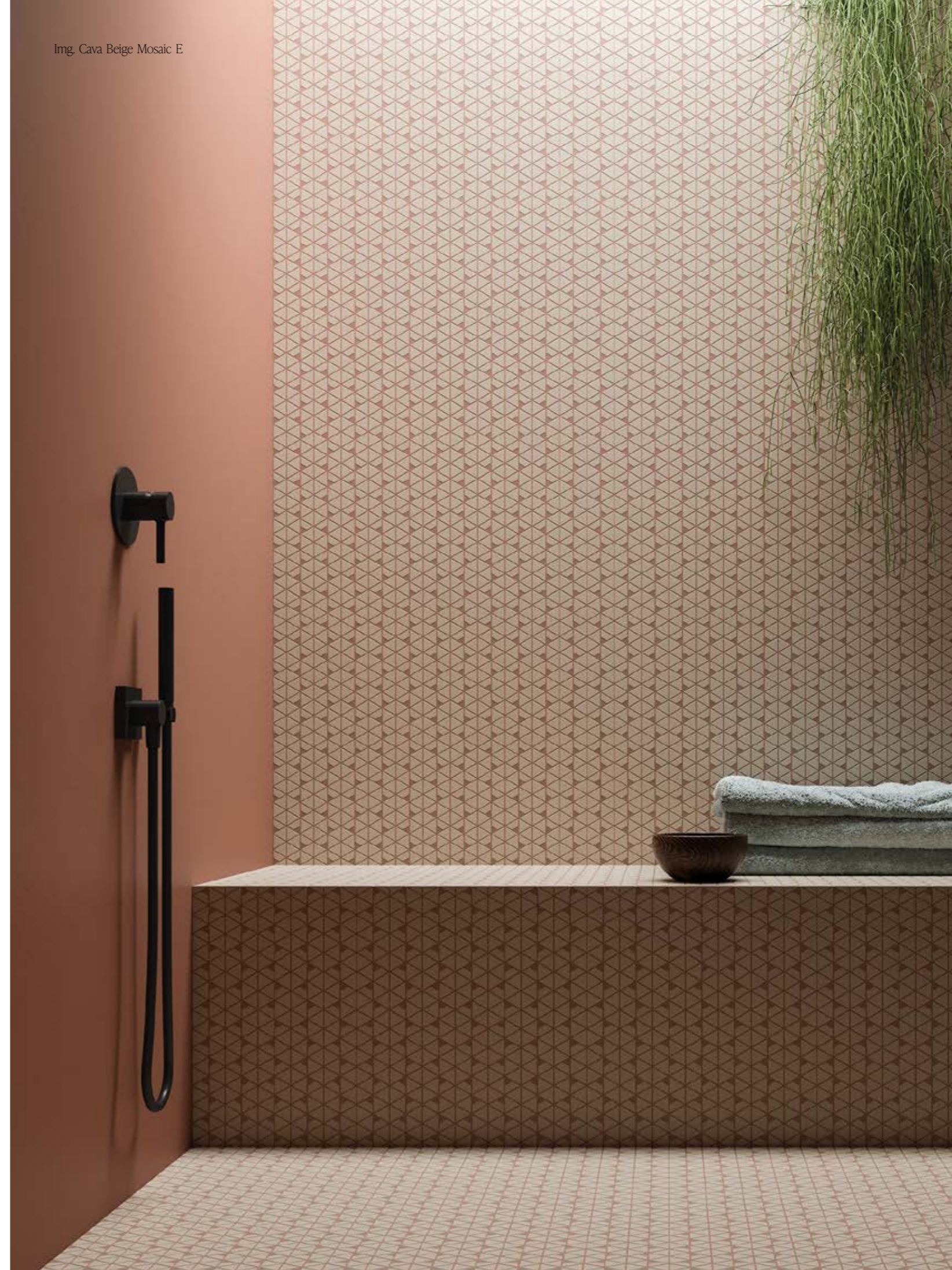



Img. Cava, Mosaic D, White



Img. Cava, Mosaic C, Brown



Echoes of the outside

NUER

[Col.]

Kensaku Oshiro



EN

Born in a time of stillness, Nuer is a silent tribute to nature as memory—not as imitation, but as a reimagined presence. The collection does not seek to represent landscapes, but to distill their essence: the light before nightfall, the rhythm of wind through trees, the calm of distance. Its pleated design and chromatic gradients breathe gently, shifting with each step, like shadows sliding through time.

Raised in Okinawa and trained in Milan, Kensaku Oshiro designs from the balance between two cultures: the reflective stillness of Japan and the precision of Italian design. Since 2015, he has led his own studio, following collaborations with renowned international brands such as Poltrona Frau and Boffi. Each of his designs begins in serene contemplation. His work breathes a silent elegance that needs no explanation. Every line is a contained decision; every texture, a presence shaped with care. Nothing is missing, nothing is in excess. As in "iki", beauty lies in the exact gesture—in what is sensed more than what is shown. For Kensaku Oshiro, design is an act of subtlety: a way of inhabiting the world with calm, with intention, with respect.

ES

Nacida en un tiempo de quietud, Nuer es un homenaje silencioso a la naturaleza como recuerdo—no como imitación, sino como una presencia reimaginada. La colección no busca representar paisajes, sino destilar su esencia: la luz antes del anochecer, el ritmo del viento sobre los árboles, la calma de la distancia. Su diseño plisado y las gradaciones cromáticas respiran suavemente, cambiando con cada paso, como las sombras que se deslizan con el tiempo.

Originario de Okinawa y formado en Milán, Kensaku Oshiro diseña desde el equilibrio entre dos culturas: la pausa reflexiva de Japón y la precisión del diseño italiano. Desde 2015 dirige su propio estudio, tras haber colaborado con reconocidas marcas internacionales tales como Poltrona Frau o Boffi. Cada uno de sus diseños nace de una contemplación serena. Su obra respira esa elegancia silenciosa que no necesita explicación. Cada línea es una decisión contenida; cada textura, una presencia pensada. Nada sobra, nada falta. Como en el "iki", la belleza está en el gesto justo, en lo que se intuye más que en lo que se muestra. Diseñar, para Kensaku Oshiro, es un acto de sutileza: una forma de habitar el mundo con calma, con intención, con respeto.



Colours available.
Colores disponibles.

White Body - Pasta Blanca

Sunset Clay Magic Hour Sand

Moss Marine Quartz Fog

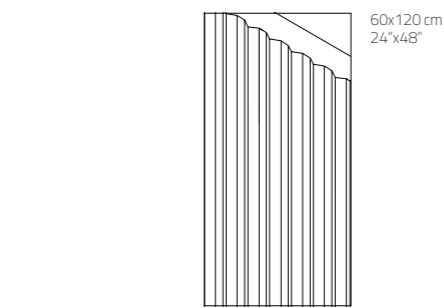

Available sizes & finishes.
Formatos y acabados disponibles.

Rectified - Rectificado
Number of designs by format: | Número de diseños por formato:
60x120: 1

Nominal Size Formato Nominal	Real Size Formato Real	Price Code	Pz/Box	M2/Box	Kg/Box	Box/Pa	M2/Pa	Kg/Pa
60x120 cm 24"x48"	59,8x119,8x0,9 cm	52	2	1,43	22,16	36	51,48	817

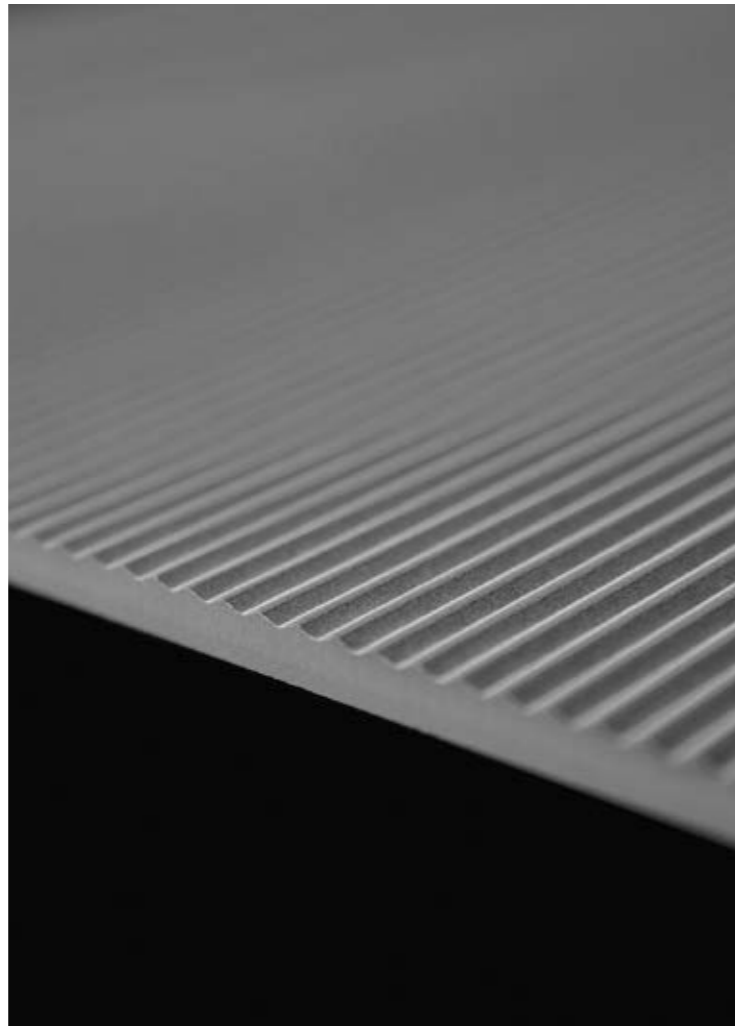



Together, we redefine
the essential by transforming
matter into tangible poetry.

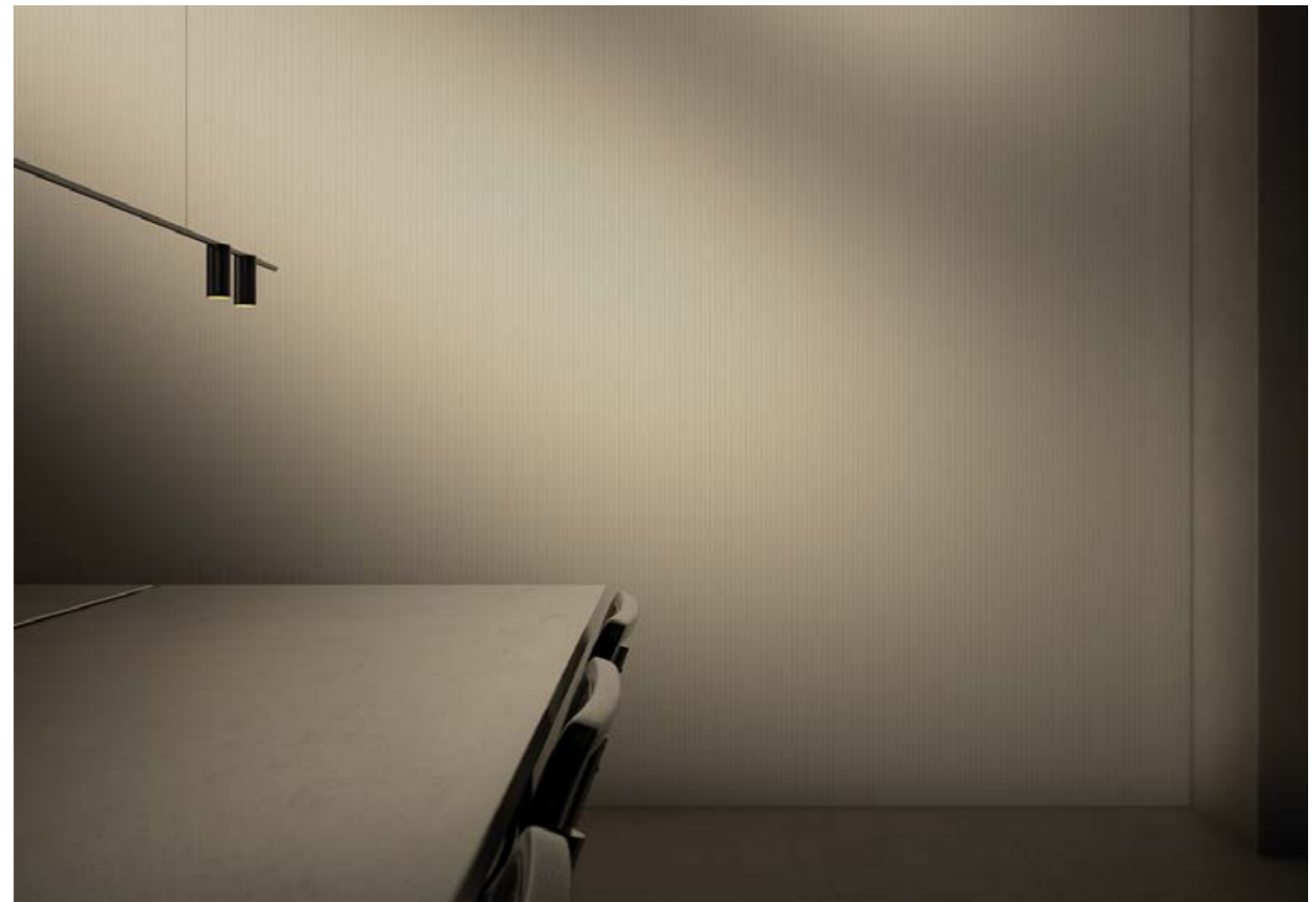

THE ARCHITECTURE
OF DETAIL

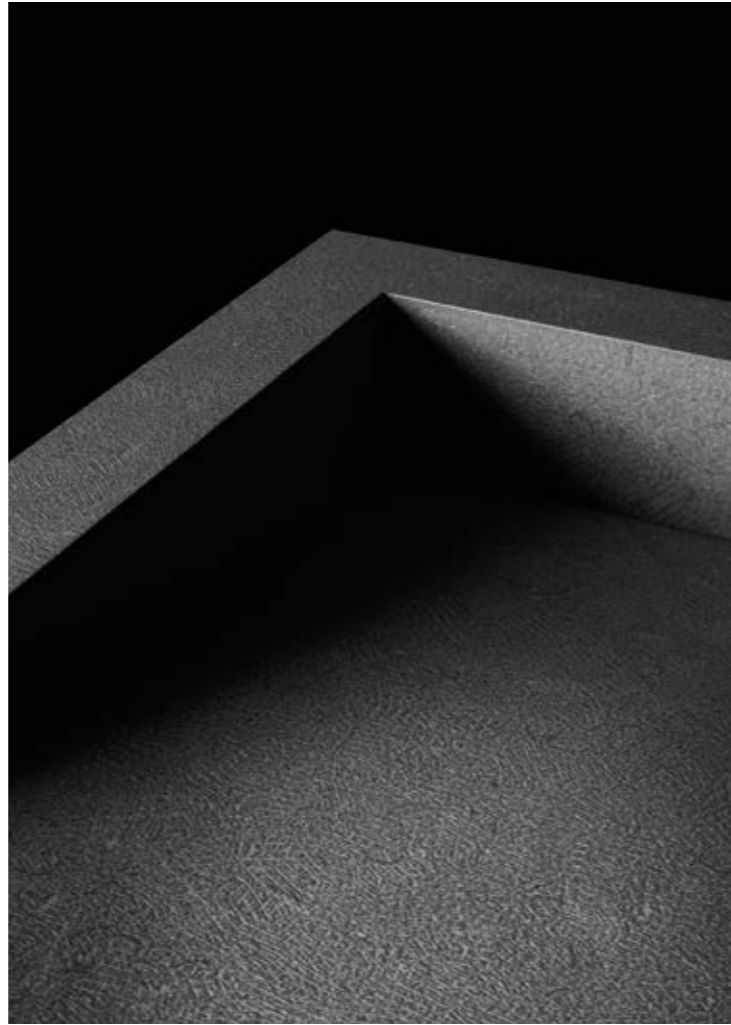



THE PRODUCTION

[I]

ES.

We redefine ceramics from two perspectives that enrich one another: the creative freedom to imagine new possibilities and the technical precision required to bring them to life. Every texture and every design emerge from this balance between vision and method, between creativity and engineering. None of this would be possible without our team. Their expertise –combining know-how, sensitivity and mastery of specialized industrial processes– supports every project. The result is a workflow where human judgement and technical accuracy work together, transforming ceramics into a material capable of meeting the demands of contemporary architecture.

Technology enables us to work with minimal tolerances, optimize parameters such as density, pressure and temperature, and ensure chromatic consistency, precise relief definition and dimensional stability. But it is our people who oversee the entire process, fine-tune decisions and ensure that each piece meets our standards.

ES.

Redefinimos la cerámica desde dos perspectivas que se equilibran entre sí: la libertad creativa de imaginar nuevas posibilidades y la precisión técnica necesaria para llevarlas a cabo. Cada textura y cada diseño surgen de esta combinación entre visión y método, entre creatividad e ingeniería.

Nada de esto sería posible sin nuestro equipo. Su experiencia –que une saber hacer, sensibilidad y dominio de procesos industriales especializados– sustenta cada proyecto. El resultado es un proceso donde el criterio humano y la exactitud técnica se complementan, convirtiendo la cerámica en una herramienta preparada para responder a las exigencias de la arquitectura contemporánea. La tecnología nos permite trabajar con tolerancias mínimas, optimizar parámetros como densidad, presión y temperatura, y asegurar continuidad cromática, precisión en los relieves y estabilidad dimensional, pero son las personas quienes controlan todo el proceso.



EN

Building on this foundation, we develop different ceramic product typologies to meet current professional requirements: Lithotech sintered stone, Ductile, with its large format and minimal thickness; our high-performance technical porcelain; and custom technical pieces designed to resolve specific junctions in architecture and interior design. All of them offer high levels of stability, dimensional precision, resistance and long-term performance, ensuring that projects can be executed with the quality, reliability and versatility that contemporary construction demands.

Our commitment to sustainability is integrated into every stage of production. We optimize energy consumption, reduce waste and work with responsibly sourced raw materials and resources. We also use recyclable packaging and develop solutions that minimize environmental impact without compromising technical performance. Even this catalogue is printed on FSC-certified papers that guarantee responsible forest management. At Livingceramics, innovation is not an isolated gesture but a continuous process: a combination of knowledge, technology and responsibility that drives our evolution with every collection.

ES

Sobre esta base desarrollamos distintas tipologías de producto que responden a las exigencias actuales: nuestra piedra sinterizada Lithotech para encimeras; Ductile, con su gran formato y mínimo espesor; nuestro porcelánico técnico de alto rendimiento; o las piezas técnicas a medida destinadas a resolver encuentros específicos en arquitectura e interiorismo. Todas ellas mantienen prestaciones elevadas en estabilidad, precisión dimensional, resistencia y comportamiento en uso, garantizando que los proyectos puedan ejecutarse con la calidad, la fiabilidad y la versatilidad que demanda la construcción contemporánea.

Nuestro compromiso con la sostenibilidad está integrado en todo el proceso. Optimizamos consumos energéticos, reducimos residuos y trabajamos con materias primas y recursos gestionados de forma responsable. También utilizamos embalajes reciclables y desarrollamos soluciones que minimizan el impacto ambiental sin comprometer el rendimiento técnico del material. Incluso este catálogo está impreso en papeles FSC que garantizan una gestión forestal adecuada. En Livingceramics, la innovación no es un gesto aislado, sino una continuidad: la suma de conocimiento, tecnología y responsabilidad que impulsa nuestra evolución en cada colección.

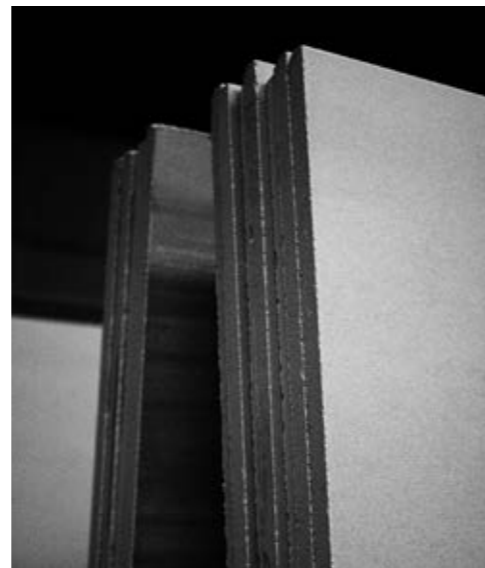



TECHNICAL SOLUTIONS

[II]











EN.

The mosaic is an essential unit: small in scale, infinite in possibility. A module that, on its own, may seem discreet, yet gains new meaning when combined with others. Each individual piece contributes its own rhythm to the composition: elements that repeat, align and interweave to create surfaces rich in nuance and depth.

At Livingceramics, we offer mosaic designs that form part of our core catalogue, while also opening the door to new configurations through our customisation and made-to-measure systems. Here, the smallest elements do not limit expression; they multiply it, extending the language of ceramic material.

ES.

El mosaico es esa unidad esencial: pequeño en escala, infinito en posibilidades. Un módulo que, por sí solo, parece discreto, pero que al unirse a otros adquiere un nuevo sentido. Cada listelo o tesela aporta su propio ritmo a la composición. Piezas que se repiten, se ordenan y se combinan para crear superficies llenas de matices y profundidad. En Livingceramics contamos con modelos que ya forman parte de nuestro catálogo esencial y, al mismo tiempo, abrimos la puerta a nuevas configuraciones gracias a nuestro sistema de personalización y diseño a medida. Aquí, lo pequeño no limita: multiplica, como una forma de ampliar el lenguaje del material cerámico.

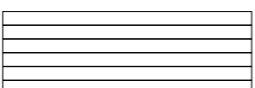
[01]	DECO MOSAIC	Net 24"x24" Malla 60x60 cm Real 59,8x59,8 cm	
[02]	MOSAIC 25	Net 12"x12" Malla 30x30 cm Real 29,8x29,8 cm	
[03]	MOSAIC 55	Net 12"x12" Malla 30x30 cm Real 29,8x29,8 cm	
[04]	MOVED MOSAIC	Net 12"x12" Malla 30x30 cm Real 29,8x29,8 cm	
[05]	MOSAIC 315	Net 12"x12" Malla 30x30 cm Real 29,8x29,8 cm	
[06]	MURETO MOSAIC	Net 12"x18" Malla 30x45 cm Real 29,8x44 cm	
[07]	SPIKE MOSAIC	Net 12"x18" Malla 30x45 cm Real 29,4x43,5 cm	
[08]	MOSAIC 330	Net 12"x12" Malla 30x30 cm Real 29,8x29,8 cm	
[09]	MOSAIC 590	Net 12"x36" Malla 30x90 cm Real 29,8x89,8 cm	

	Price Code	Pz/Box	M2/Box	Kg/Box	Box/Pa	M2/Pa	Kg/Pa
Deco Mosaic	560	4	0,92	20,00	24	22,10	510
Mosaic 25	25	5	0,44	9,00	60	26,40	585
Mosaic 55	55	5	0,44	9,00	60	26,40	585
Moved Mosaic	302	5	0,44	9,00	60	26,40	576
Mosaic 315	315	5	0,44	9,00	60	26,40	585
Mureto Mosaic	300	5	0,44	9,00	40	17,60	404
Spike Mosaic	303	5	0,47	10,75	40	18,80	465
Mosaic 330	330	5	0,44	10,50	60	26,40	675
Mosaic 590	590	3	0,81	18,30	20	16,20	407

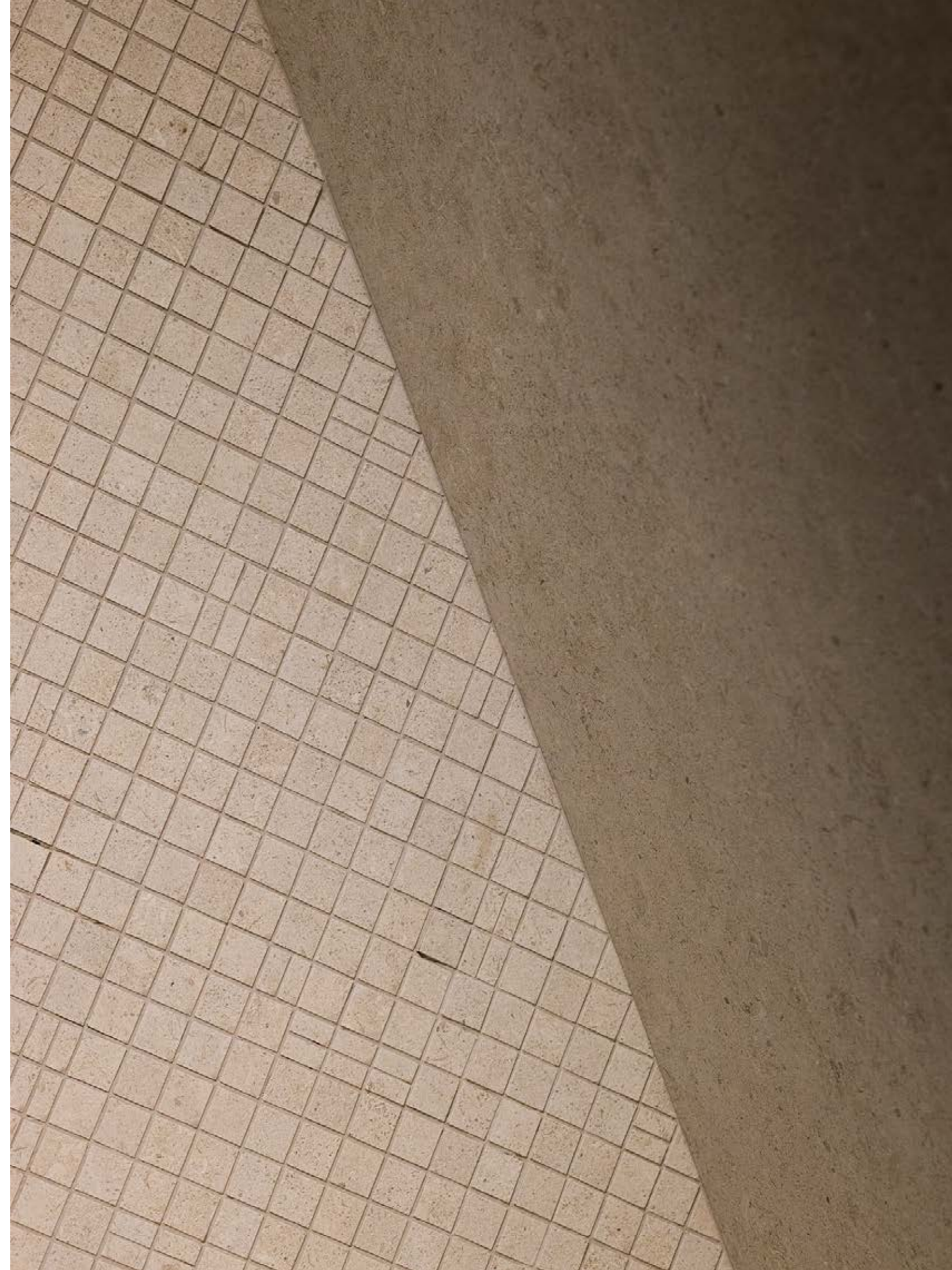



20mm THICKNESS

EN.

Each project demands materials capable of going beyond functionality. Livingceramics' 20 mm thick porcelain stoneware meets this need: a surface that fuses technical innovation with aesthetic sensitivity, offering safe, durable solutions with timeless beauty to design without limits.

This double technical thickness is specially conceived for outdoor use, where resistance to heavy loads and temperature changes is essential even under the most demanding conditions. Available in 90x90 cm and 120x120 cm formats, and featuring an anti-slip finish, the 20 mm range joins some of our most emblematic collections, reinforcing their versatile and timeless character, and opening the possibility of conceiving in&out spaces with serene, seamless continuity.

ES.

Cada proyecto exige materiales capaces de ir más allá de lo funcional. El gres porcelánico de 20 mm de espesor de Livingceramics responde a esa necesidad: una superficie que fusiona innovación técnica y sensibilidad estética, ofreciendo soluciones seguras, duraderas y con una belleza atemporal para diseñar sin límites.

Este doble espesor técnico está especialmente concebido para exteriores, donde la resistencia frente a cargas y cambios de temperatura resulta esencial incluso en las condiciones más exigentes. Disponible en formatos de 90x90 cm y 120x120 cm, y con acabado antideslizante, el formato de 20 mm se suma a algunas de nuestras colecciones más emblemáticas, reforzando su carácter versátil y atemporal, y abriendo la posibilidad de concebir espacios in&out con una continuidad serena y sin barreras.

Dimensions



Applications

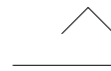

EN
Our 20mm-thick collections have the same design as the 9mm-thick tile series by Livingceramics. This means that matching tiles can be used both indoors and out, ensuring seamless visual continuity. This is a definite asset in the design of spaces for residential, leisure or public use.

ES
Nuestras colecciones de 20mm mantienen el diseño de las Series de 9mm de Livingceramics. Por tanto, ofrecen la posibilidad de emplear el mismo material tanto en la zona interior como en la exterior, haciendo desaparecer los límites entre áreas y ofreciendo así continuidad visual al espacio. Una cualidad muy valorada a la hora de diseñar espacios como residenciales, zonas de ocio o espacios públicos.



EN
Thanks to the high resistance and inalterability of our 20mm-thick porcelain tiles, they are ideal for places subject to adverse conditions and extreme temperatures, such as covered terraces, gardens or patios.

ES
Las cualidades técnicas de resistencia e inalterabilidad que presenta el gres porcelánico de 20mm lo hacen idóneo para revestir las áreas más expuestas a condiciones adversas: zonas de exterior como porches, jardines o terrazas en las que las temperaturas extremas inciden de manera directa.



EN
All our 20mm-thick tile series are non-slip, guaranteeing a safe grip in wet areas or places close to water, such as poolside terraces. Likewise, the tiles are non-porous; that is, they do not absorb water and so they will not crack. What is more, they do not require any kind of special treatment.

ES
Todas nuestras series disponibles en 20mm cuentan con acabado anti slip, destinado a garantizar la seguridad en zonas húmedas o cercanas al agua, como los bordes de las piscinas. Asimismo, al tratarse de un material no poroso, no absorbe agua y, por tanto, no se agrieta y no requiere de tratamientos específicos.



EN
In order to ensure visual continuity between indoor and outdoor areas and to fit in with the needs of each individual project, extra-thick special porcelain tile pieces are available, such as step tiles, skirting tiles, corner tiles and finishing pieces. The range's high versatility contributes to projects' visual coherence.

ES
Con el fin de mantener la continuidad estética entre los espacios interiores y exteriores y adaptarse a cada proyecto, el gres porcelánico espesorado se utiliza en piezas especiales como peldaños, zócalos, ángulos y remates cerámicos. La elevada versatilidad del material facilita la coherencia visual en el resultado final del proyecto.



Advantages

EN.

Extra-thick porcelain tiles offer numerous benefits, thanks to their versatility and high resistance. These are properties fully able to meet the tough technical demands and aesthetic requirements of outdoor spaces, public areas, and places subject to high loads or stresses.

The tiles can be used in false floor systems, creating raised access flooring that provides easy access to plumbing and electricity networks. They are swift and easy to lay, and the perfect choice for outdoor areas.

ES.

El gres porcelánico espesorado ofrece múltiples ventajas gracias a su elevada resistencia y versatilidad. Características que responden a las más altas exigencias a nivel técnico y estético que requieren zonas de exterior, áreas públicas y zonas sometidas a altas cargas y tensiones.

Permite su ejecución en sistemas registrables, ofreciendo suelos técnicos elevados fácilmente accesibles a instalaciones de fontanería y electricidad. Rápido y fácil en su ejecución, se trata de un material perfecto para el pavimentado de exteriores.

BREAKING STRENGTH
Resistencia a la flexión



BREAK RESISTANCE
Resistencia a la rotura



WATERPROOF MATERIAL
Material impermeable



UV RESISTANT
Resistencia a los rayos UV



FROST RESISTANT
Resistencia a climas extremos



RESISTANT TO CHEMICAL AGENTS AND DETERGENTS
Resistencia a los agentes químicos y detergentes



EASY TO CLEAN
Fácil limpieza



REUSABLE AND ACCESSIBLE
Registrable y reutilizable



FAST INSTALLATION
Rápida colocación



EASY TO INSTALL
Fácil instalación



COLOUR STABILITY
Estabilidad cromática



Systems

[01]

CONVENTIONAL TILE-LAYING SYSTEMS

This is the most common system for creating flooring able to withstand high pedestrian traffic or moving vehicles in garages or up and down entrance ramps. The tiles are laid in a similar way to standard porcelain floor tiles, although the necessary joints for outdoor areas must be inserted.

SISTEMA DE COLOCACIÓN TRADICIONAL

Es la instalación más normalizada para conseguir un sistema capaz de absorber grandes tránsitos peatonales o paso de vehículos en garajes y rampas de acceso. Su ejecución es similar a la de un pavimento porcelánico, manteniendo especial atención a las juntas recomendadas en zonas exteriores.

[02]

ON LAWNS, SAND OR GRAVEL

These dry-installation systems are very common in outdoor areas. The main benefit is the swift installation method with no need for any kind of chemical adhesive. This makes it both simple and economical.

Whether the tiles are to be laid on grass, gravel or sand, they must be supported by an approximately 6cm-thick bed of gravel with a 4 to 8mm particle size.

SOBRE CÉSPED, ARENA O GRAVA

Estos sistemas de colocación en seco son muy comunes en las zonas de exterior. Su mayor ventaja es su colocación rápida y sin ningún tipo de adhesivo químico, por lo que resulta un sistema económico y fácil de acometer.

Tanto si queremos realizar una instalación sobre césped, como si lo hacemos sobre gravilla o arena, deberemos tener en cuenta que la pieza deberá descansar sobre un lecho de unos 6 cm. de espesor de una gravilla de granulometría 4-8 mm.

[03]

ON PLOTS

Our 20mm-thick tiles can be rested on pedestals to create raised-access flooring (RAF). This swift, adhesive-free installation system allows networks to be concealed under the floor, such as wiring or pipes. Used in conjunction with conventionally laid tile surfaces and thanks to the large formats that Livingceramics offers, visual continuity can be ensured; for instance, to create terraces or in projects for the contract market.

SOBRE PLOTS

La instalación del porcelánico espesorado 20mm. sobre plots, crea un sistema de Suelo Técnico Elevado (STE) que permite una instalación libre de adhesivos, de ejecución rápida y con la ventaja de poder realizar una instalación bajo el pavimentado, capaz de albergar cableado o tuberías. Junto con el sistema tradicional, y gracias al gran formato ofrecido por Livingceramics, permite instalaciones de una continuidad visual óptima en terrazas y proyectos contract.



Available products

ALLURE

Marbled stone in ceramics
Piedra veteada cerámica



BERA&BEREN

Lusitan&Catalan limestone ceramics
Caliza Lusitana&Catalana cerámica



FRAME

Northern stone in ceramics
Piedra del norte cerámica



GUBI

Microcement ceramics
Microcemento cerámico

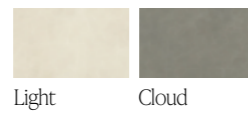

KENDO

Jura stone in ceramics
Piedra Jura en cerámica



NOON

Northern stone in ceramics
Piedra del norte cerámica



ODA

French stone in ceramics
Piedra francesa en cerámica



STILL

Microcement ceramics
Microcemento cerámico



VERSO CROSS CUT

Travertine stone in ceramics
Piedra travertino en cerámica



VERSO VEIN CUT

Travertine stone in ceramics
Piedra travertino en cerámica



VONN

Textured stone in ceramics
Piedra texturada en cerámica



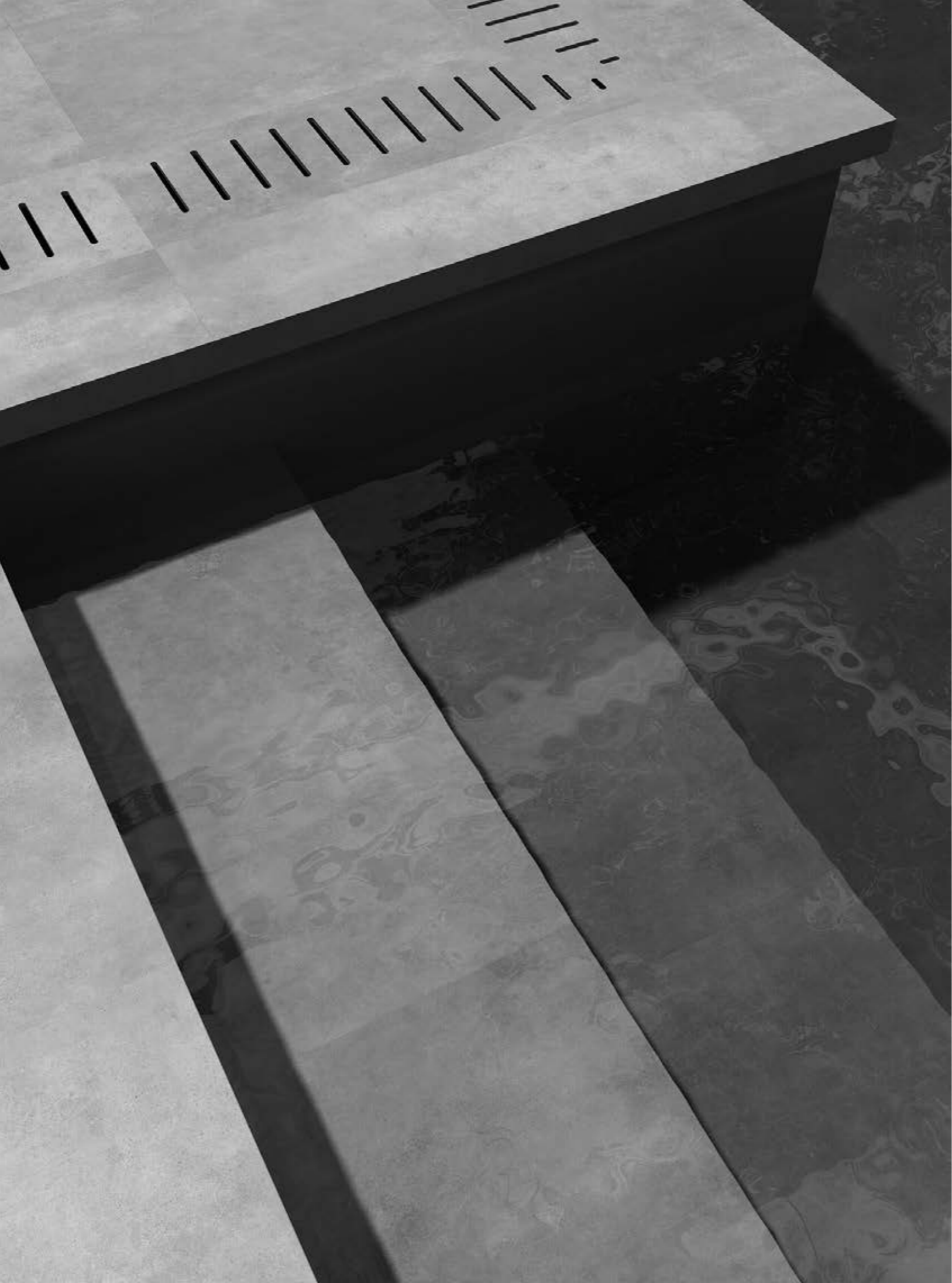

TECHNICAL PIECES

EN.

Every project presents its own requirements. For this reason, our way of working always begins with adaptation, developing a system of technical pieces tailored to the dimensions, uses and details each project demands. As a starting point, we propose a selection of standard solutions. From there, formats, edge profiles and finishes can be freely combined to create bespoke technical pieces, fully aligned with the design of each project.

ES.

Cada proyecto plantea sus propias necesidades. Por eso, nuestra forma de trabajar parte siempre de la adaptación, ofreciendo un sistema de piezas técnicas pensado para ajustarse a las dimensiones, los usos y los detalles de cada espacio. Como punto de partida, proponemos una serie de soluciones habituales. A partir de ellas, formatos, cantos y acabados pueden combinarse libremente para dar forma a piezas técnicas a medida, en coherencia con el diseño del proyecto.

[01] TYPE OF PIECE | TIPO DE PIEZA

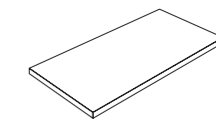

*Stair tread border.
Peldaño borde.*

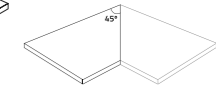

*Stair tread left border.
Peldaño ángulo izquierda.*

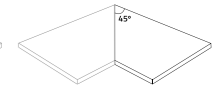

*Stair tread right border.
Peldaño ángulo derecha.*

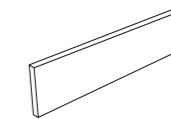

*Stair riser or skirting.
Tabica o zócalo.*

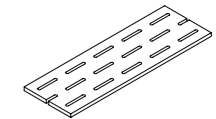

*Pool grid type A.
Rejilla piscina tipo A.*

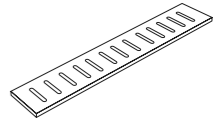

*Pool grid type B.
Rejilla piscina tipo B.*

[02] TYPE OF EDGE | TIPO DE BORDE

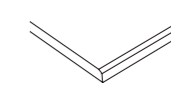

*Single straight.
Recto simple.*

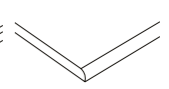

*Demi bullnose.
Medio roma.*

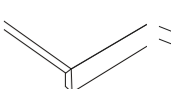

*Mitred.
Ingeletado.*

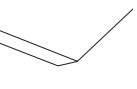

*45° edge.
Canto 45°.*

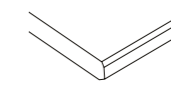

*Double straight.
Recto doble.*

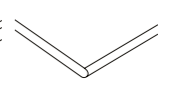

*Bullnose.
Roma.*

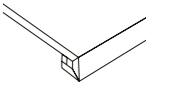

*Gradone.
Ingeletado doble.*

[03] EXTRA

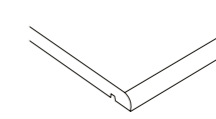

*Include drip edge.
Incluir "goterón".*

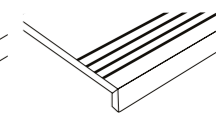

*Include extra grip.
Incluir extra agarre.*



The architecture of detail



LITHOTECH

[III]

EN.

Under a shared philosophy and a singular way of understanding design, we present Lithotech: our high-performance technical sintered stone, conceived to offer functional, stable, and visually refined surfaces for architecture and interior design.

What is Lithotech? A technical porcelain produced through advanced ultra-compaction processes and high-temperature thermal treatments. This combination achieves superior levels of strength, chromatic stability, and durability while maintaining a consistent appearance throughout the entire thickness of the slab. The result is a non-porous, hygienic material that is easy to clean and highly resistant to scratching, staining, chemical agents, and high temperatures – properties that make it a solid and stable solution even under the most demanding conditions of use. Yet the technical capacity of Lithotech goes beyond its manufacturing process. Its versatility expands the boundaries of design: from kitchen and bathroom countertops to technical furniture, wall cladding, large-format surfaces, and bespoke architectural applications. Its uniform composition and the visual continuity of its edges enable the creation of projects with complete aesthetic and functional coherence.

ES.

Bajo una misma filosofía y una única forma de entender el diseño, presentamos Lithotech: nuestra propuesta de piedra sinterizada de alto rendimiento, concebida para ofrecer soluciones funcionales, estables y visualmente cuidadas en arquitectura e interiorismo. ¿Qué es Lithotech? Un porcelánico técnico obtenido mediante procesos avanzados de ultracompactación y tratamientos térmicos a altas temperaturas. Esta combinación permite alcanzar niveles de resistencia, estabilidad cromática y durabilidad muy superiores, manteniendo siempre una apariencia uniforme en todo el espesor de la pieza. El resultado es un material no poroso, higiénico, fácil de limpiar y altamente resistente al rayado, a las manchas, a los productos químicos y a las altas temperaturas. Prestaciones que lo convierten en una solución sólida y estable incluso en las condiciones más exigentes de uso. Pero la capacidad técnica de Lithotech no se limita a su proceso de fabricación. Su versatilidad amplía las posibilidades de diseño: desde encimeras de cocina y baño hasta mobiliario técnico, revestimientos, piezas de gran formato y soluciones específicas para arquitectura. Su comportamiento uniforme y la continuidad visual de sus bordes permiten desarrollar proyectos con una completa coherencia estética y funcional.

Product equivalencies
Livingceramics & Lithotech

ALLURE

Marbled stone in ceramics
Piedra veteadada cerámica

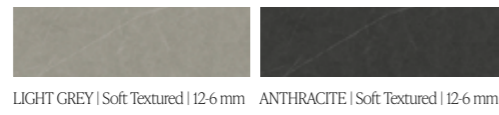

BERA&BEREN

Lusitan&Catalan limestone ceramics
Caliza Lusitana&Catalana cerámica



DUE

Natural brushed oak in ceramics
Roble natural cepillado en cerámica

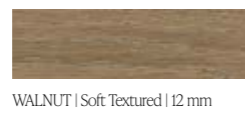

FRAME

Northern stone in ceramics
Piedra del norte cerámica



GUBI

Microcement ceramics
Microcemento cerámico

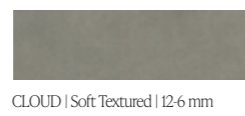

KENDO

Jura stone in ceramics
Piedra Jura en cerámica



ODA

French stone in ceramics
Piedra francesa en cerámica



VERSO CROSS CUT

Travertine stone in ceramics
Piedra travertino en cerámica



VERSO VEIN CUT

Travertine stone in ceramics
Piedra travertino en cerámica



VONN

Textured stone in ceramics
Piedra texturada en cerámica

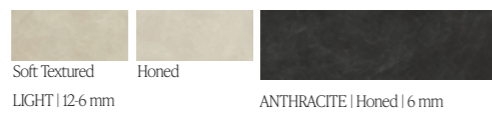

WEGA TECH

Volcanic stone in ceramics
Piedra volcánica cerámica

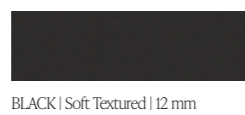





BATHROOM FURNITURE SERIES

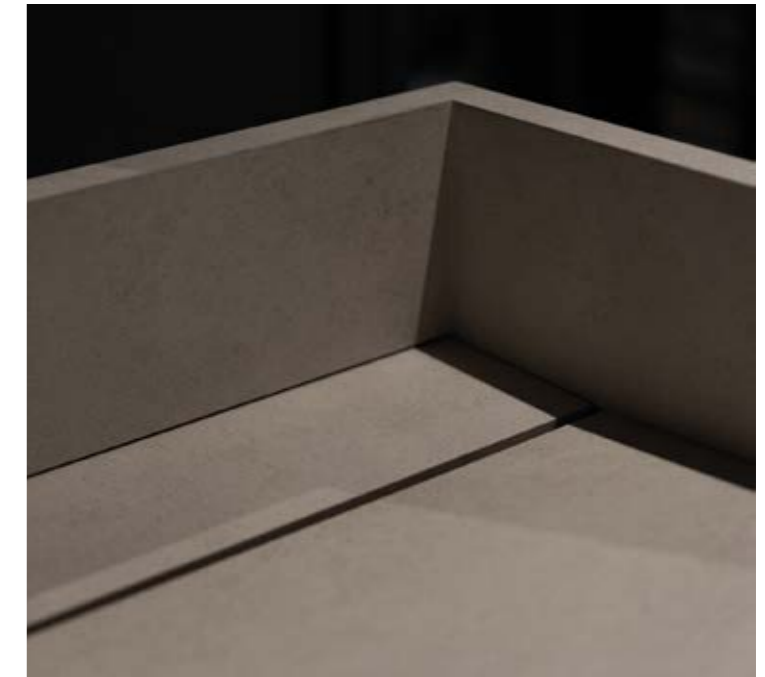

[IV]

EN.

At Livingceramics we take care of every detail, every design, embedding art in its forms and balance in its composition. We strive to give each bathroom its own identity, offering freedom in the choice of finishes and the relationship between its elements, creating an infinite range of carefully studied solutions. Colours, textures, perspectives... all complement each other to create a perfect visual balance. The essence of Livingceramics is reflected in the subtlety of each model, inspired by an in-depth study of the most inspiring architectural projects and works.

Our bathroom collection combines contemporary design with timeless elegance. This proposal includes a range of handcrafted sinks and furniture, the result of a manufacturing process that blends innovation with tradition. In this way, ceramic and wood come together as if in an endless dialogue.

With a wide variety of sizes, our pieces are designed to fit naturally into any space. Our passion for ceramics and the creation of unique elements is reflected in this collection, designed to create integrated, harmonious environments full of character.

ES.

En Livingceramics cuidamos cada detalle, cada diseño, plasmando el arte en sus formas y el equilibrio en su composición. Buscamos que cada baño tenga su identidad, dando libertad en la selección de acabados y en la relación entre sus elementos, creando un sinfín de soluciones cuidadosamente estudiadas. Los colores, las texturas, las perspectivas... se complementan entre sí para alcanzar un perfecto equilibrio visual.

La esencia de Livingceramics se refleja en la sutileza de cada modelo, inspirada en un profundo estudio de los proyectos y obras arquitectónicas más inspiradoras.

Nuestra colección de baños combina diseño contemporáneo y elegancia atemporal, esta propuesta incluye una gama de lavabos y muebles de acabado manual, fruto de un proceso de fabricación que une innovación y tradición, de esta forma, cerámica y madera conversan como en un diálogo infinito. Con una amplia variedad de formatos, nuestras piezas están diseñadas para adaptarse con naturalidad a cualquier espacio. Nuestra pasión por la cerámica y la creación de elementos únicos se refleja en esta colección, concebida para dar forma a entornos integrados, armónicos y llenos de personalidad.



Custom Design Software

EN

Designed to be your ally in design, our Custom Design Software allows you to create bespoke pieces. Starting from an initial configurator, you can customize every detail, dimensions and finishes, until you achieve an exclusive result that reflects your vision. With our ceramic collections as allies, every detail integrates seamlessly into the space, showcasing the perfect connection between design and technology. Our 3D software is so intuitive that it effortlessly brings your ideas to life, because our goal is to help you take your projects one step further.

ES

Pensado para ser tu aliado en el diseño, nuestro Custom Design Software te permite crear piezas a medida. Partiendo de un configurador inicial, puedes personalizar cada detalle, medidas y acabados, hasta lograr ese resultado único que refleje tu visión. Con nuestras colecciones cerámicas como aliadas, cada detalle se integra con naturalidad en el espacio, mostrando la perfecta conexión entre diseño y tecnología. Nuestro software 3D es tan intuitivo que convierte tus ideas en realidad sin esfuerzo, porque nuestro objetivo es ayudarte a llevar tus proyectos un paso más allá.

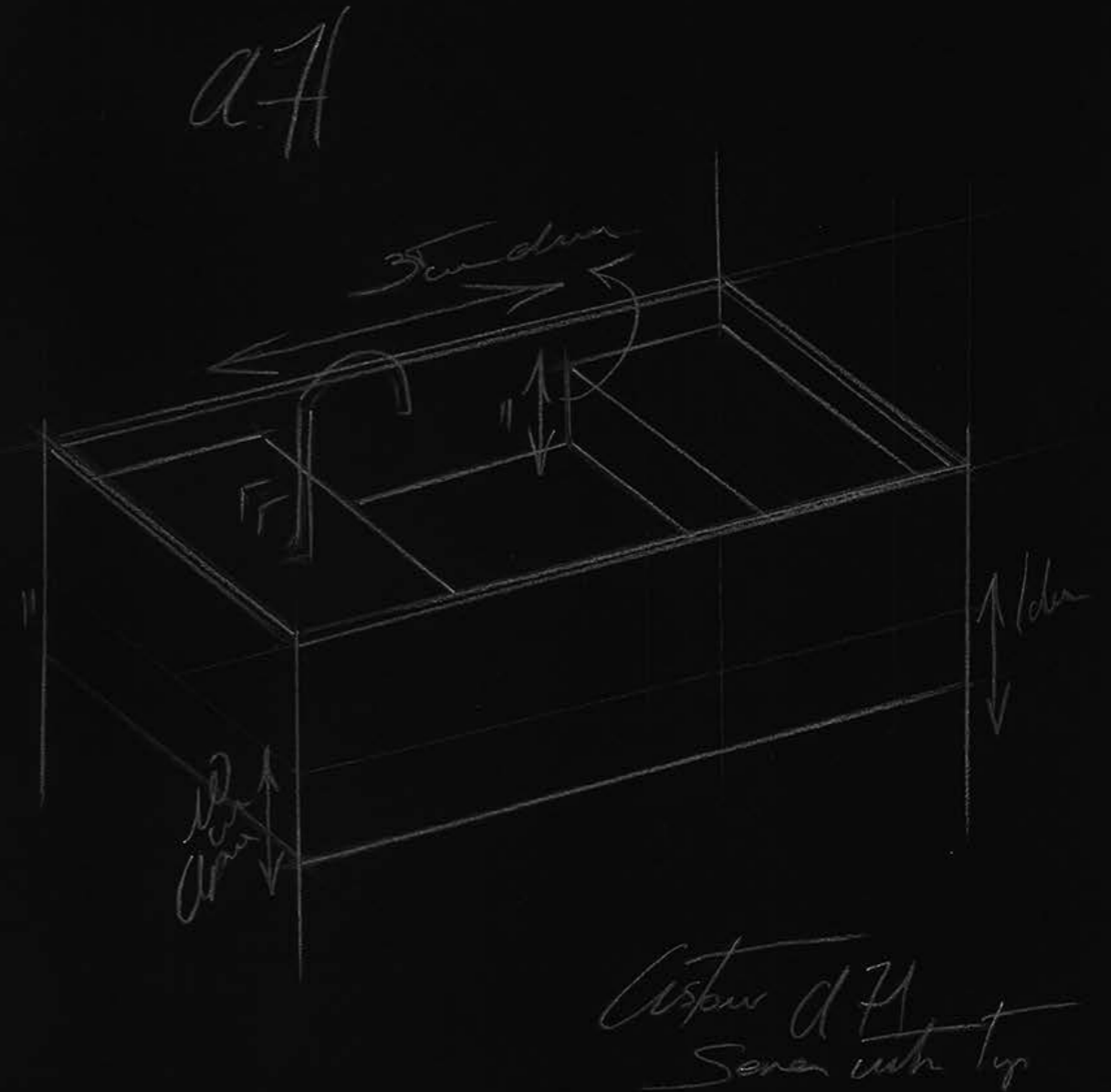
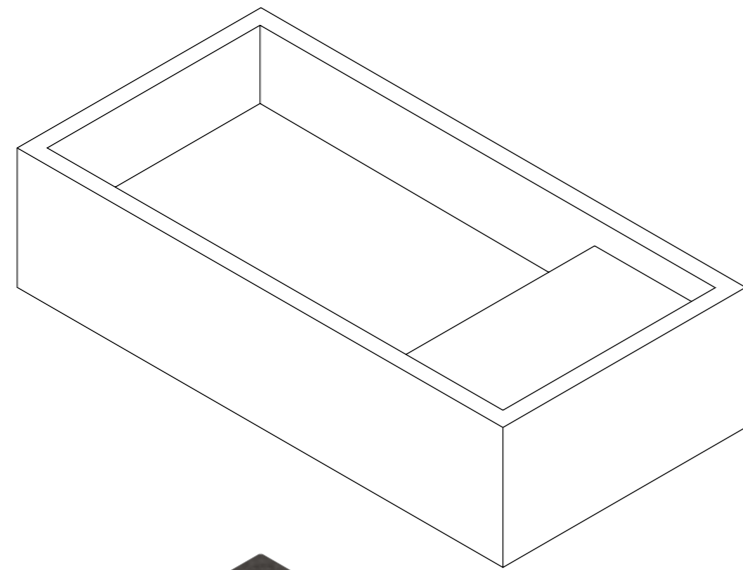

Available products

ALLURE

Marbled stone in ceramics
Piedra veteadada cerámica

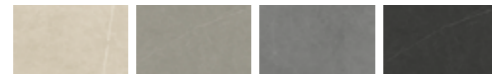

BERA&BEREN

Lusitan&Catalan limestone ceramics
Caliza Lusitana&Catalana cerámica



CUIT

Mud art in ceramics
Arte en barro cerámico



FLOSS

Natural cement ceramics
Cemento natural cerámico



FRAME

Northern stone in ceramics
Piedra del norte cerámica



GUBI

Microcement ceramics
Microcemento cerámico



KENDO

Jura stone in ceramics
Piedra Jura en cerámica



NOON

Northern stone in ceramics
Piedra del norte cerámica

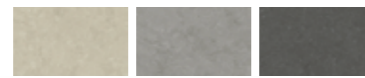

ODA

French stone in ceramics
Piedra francesa en cerámica



STILL

Microcement ceramics
Microcemento cerámico



VERSO CROSS CUT

Travertine stone in ceramics
Piedra travertino en cerámica



VERSO VEIN CUT

Travertine stone in ceramics
Piedra travertino en cerámica



VONN

Textured stone in ceramics
Piedra texturada en cerámica



KRON TECH *

Concrete in ceramics
Cemento en cerámica

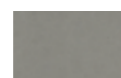

WEGA TECH *

Volcanic stone in ceramics
Piedra volcánica cerámica

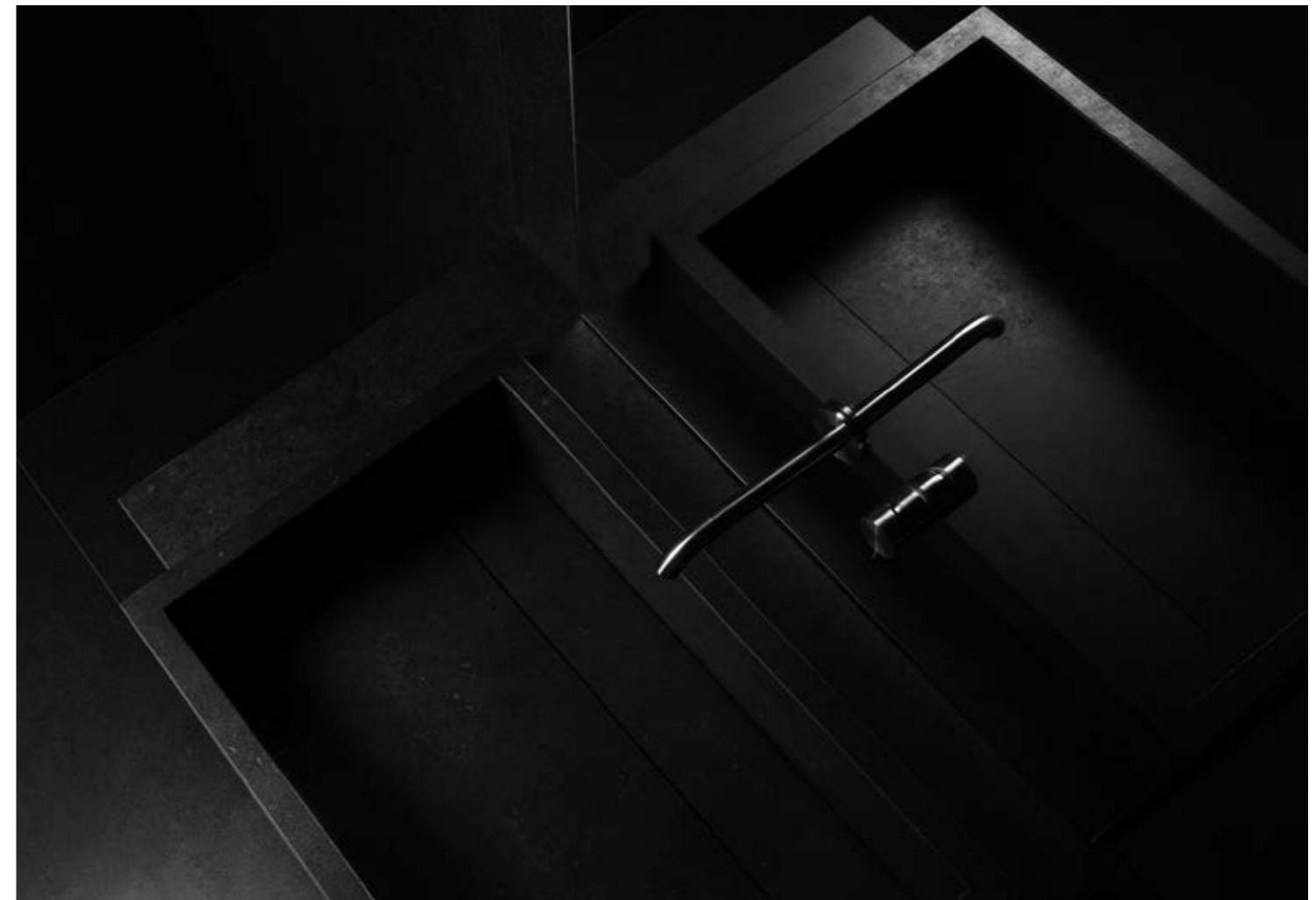

** Available only for basins measuring less than 120 cm.*
** Disponible solo para lavabos de menos de 120 cm.*



The architecture of detail



CUSTOM DESIGN HUB

[V]

We redefine ceramics from two perspectives that enrich one another: the creative freedom to imagine new possibilities and the technical precision required to bring them to life. Every texture and every design emerge from this balance between vision and method, between creativity and engineering. None of this would be possible without our team. Their expertise –combining know-how, sensitivity and mastery of specialized industrial processes– supports every project. The result is a workflow where human judgement and technical accuracy work together, transforming ceramics into a material capable of meeting the demands of contemporary architecture.

Technology enables us to work with minimal tolerances, optimize parameters such as density, pressure and temperature, and ensure chromatic consistency, precise relief definition and dimensional stability. But it is our people who oversee the entire process, fine-tune decisions and ensure that each piece meets our standards.

Redefinimos la cerámica desde dos perspectivas que se equilibran entre sí: la libertad creativa de imaginar nuevas posibilidades y la precisión técnica necesaria para llevarlas a cabo. Cada textura y cada diseño surgen de esta combinación entre visión y método, entre creatividad e ingeniería.

Nada de esto sería posible sin nuestro equipo. Su experiencia –que un saber hacer, sensibilidad y dominio de procesos industriales especializados– sustenta cada proyecto. El resultado es un proceso donde el criterio humano y la exactitud técnica se complementan, convirtiendo la cerámica en una herramienta preparada para responder a las exigencias de la arquitectura contemporánea. La tecnología nos permite trabajar con tolerancias mínimas, optimizar parámetros como densidad, presión y temperatura, y asegurar continuidad cromática, precisión en los relieves y estabilidad dimensional, pero son las personas quienes controlan todo el proceso.

Solutions for:

EN

This includes many of the customisation possibilities of the Custom Design Hub. This is a list of the most common solutions, but we can manufacture any design you need within the possibilities of ceramics. You will also find images of some of the models manufactured in our workshop. But it's not just about designs, it's about inspiration to help you find the shapes, colours and solutions that best suit your project.

ES





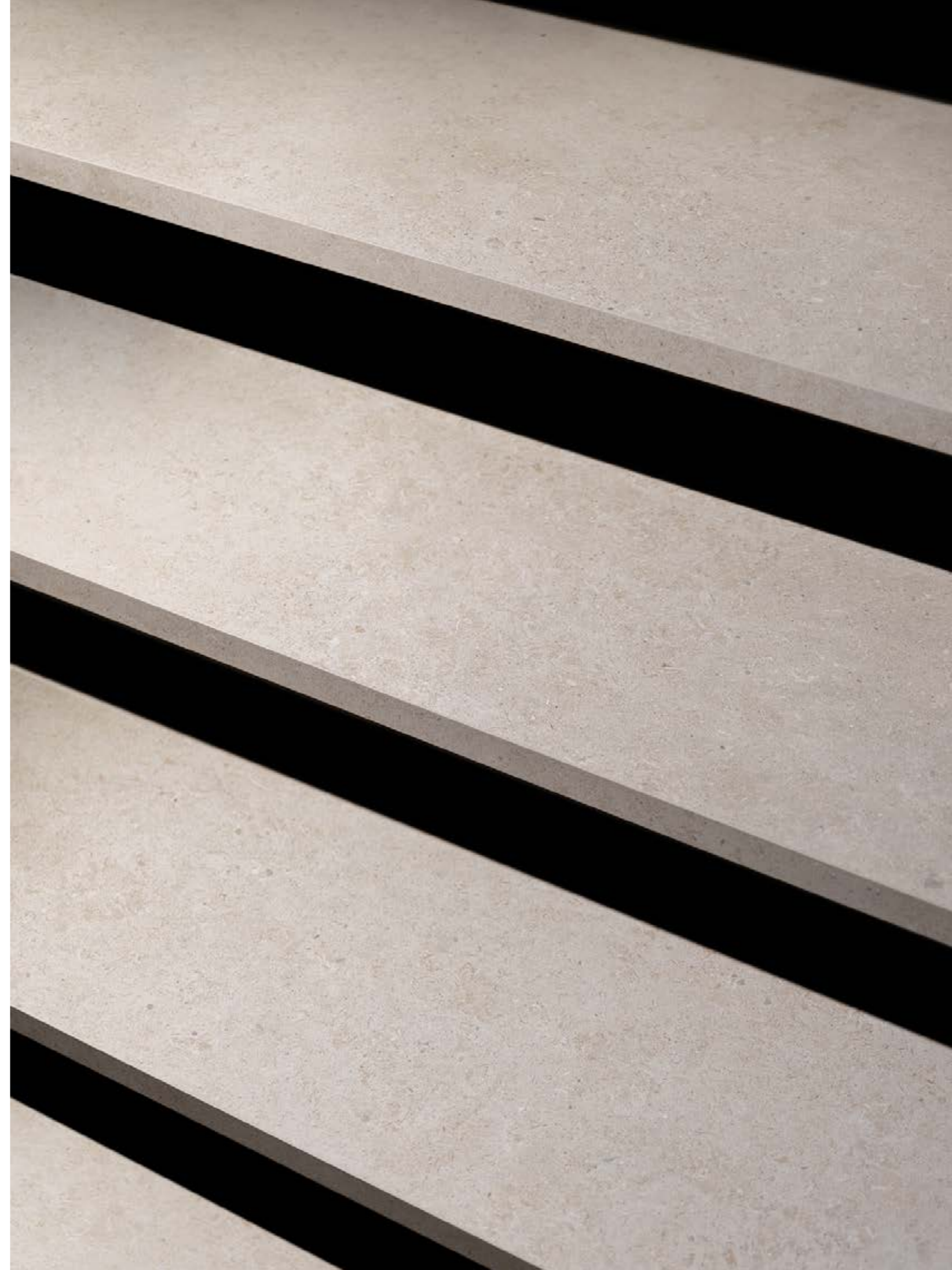





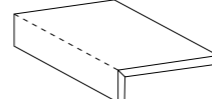

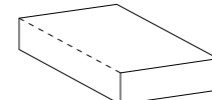

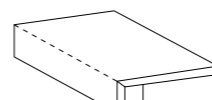

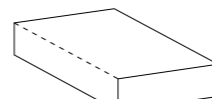

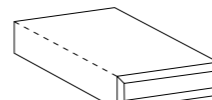

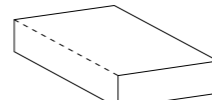

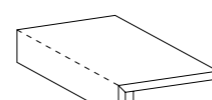

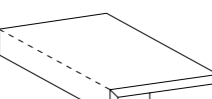

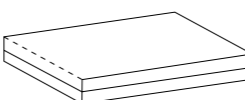

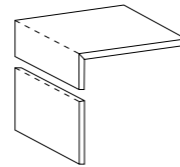
Aquí se engloban muchas de las posibilidades de personalización de Custom Design Hub. Esta es una lista con las soluciones más comunes, pero podemos fabricar cualquier diseño que necesites dentro de las posibilidades de la cerámica. Además, encontrarás imágenes de algunos modelos fabricados en nuestro taller. Pero no se trata solo de diseños, sino de inspiración para ayudarte a encontrar las formas, colores y soluciones que mejor se adapten a tu proyecto.

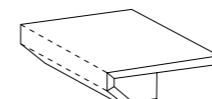
- [01] WALL & FLOORS
Cut to Size | Slotted for Hidden Clip | Facades System
- [02] FURNITURE
Reception Desks | Fireplaces | Tables | Planters | Units
- [03] BATHROOMS
Washbasins | Shower Trays | Bathtubs | Countertops
- [04] KITCHENS
Sinks | Countertops
- [05] STAIRWAYS
Steps | Handrails
- [06] SWIMMING POOLS
Customized Pool Grids | Pool-edges Pieces
- [07] SHAPES & DECORATES
Waterjet Shapes | Sandblast Decorated

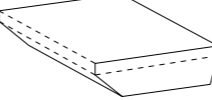

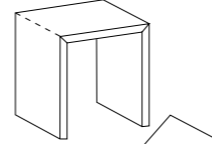

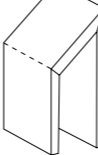
Ensembled possibilities
MITRED

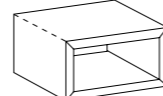
- [01] MITRED
Inglete  
- [02] CORNER MITRED
Inglete angular  
- [03] GRADONE
Inglete doble  
- [04] CORNER GRADONE
Inglete doble angular  
- [05] GRADONE DOUBLE SIDE
Inglete doble
Pieza completa  
- [06] ANGULAR GRADONE
DOUBLE SIDE
Inglete doble. Pieza completa
Angular  
- [07] MITRED VERTICAL REFORCED
Inglete reforzado en vertical  
- [08] MITRED HORIZONTAL REFORCED
Inglete reforzado en horizontal  
- [09] DOUBLE LAYER
Contracolado  
- [10] SUSPENDED MITRED
Inglete suspendido  
- [11] MITRED SHARK NOSE
Pico flauta ingletado  
- [12] MITRED CORNER SHARK NOSE
Pico flauta ingletado angular  
- [13] 3 MITRED SIDES
3 caras ingletadas  
- [14] 3 ANGLED MITRED SIDES
3 caras ingletadas en ángulo  
- [15] 4 MITRED SIDES
4 caras ingletadas  



Ensembled possibilities
EDGES

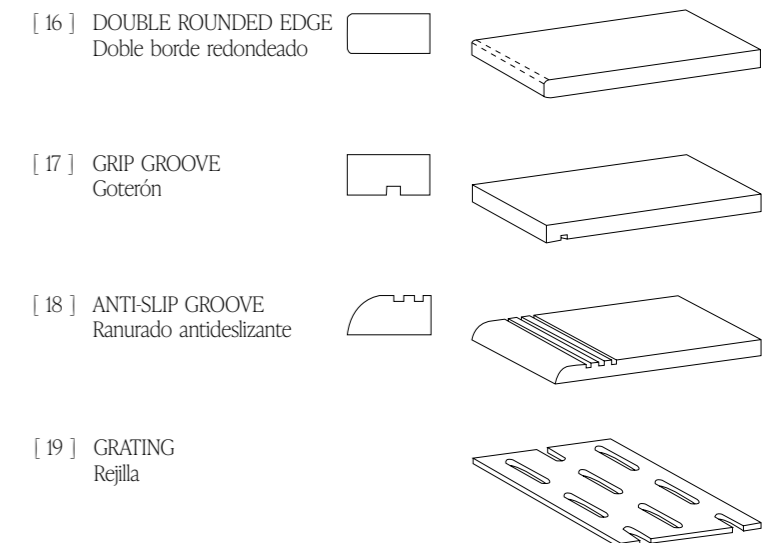
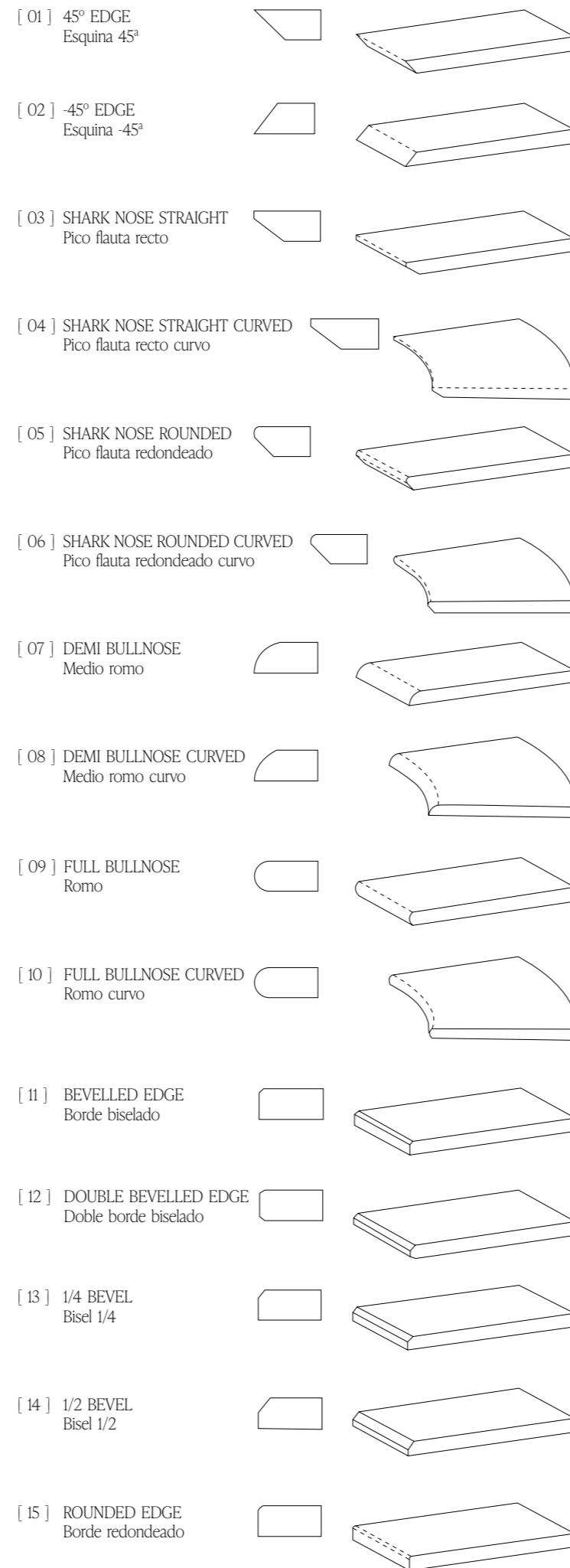

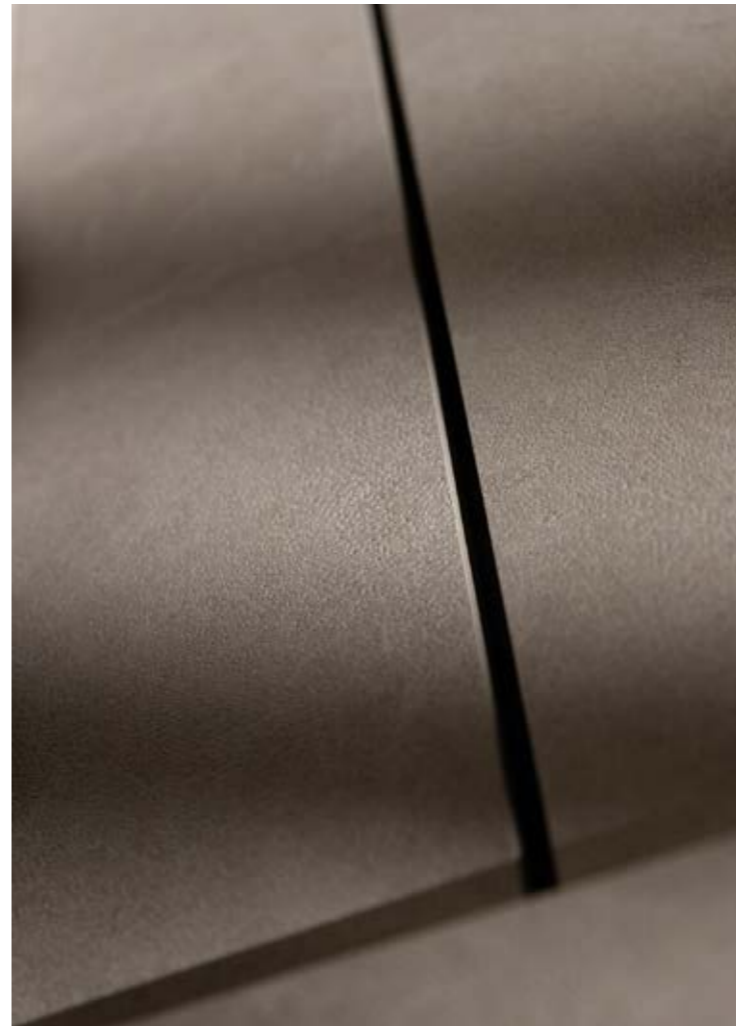



The architecture of detail



TECHNICAL INFORMATION

[VI]

EN
The following pages bring together the technical recommendations necessary for the correct installation, maintenance and use of our materials.

ES.
Las siguientes páginas reúnen las recomendaciones técnicas necesarias para la correcta instalación, mantenimiento y uso de nuestros materiales.

Installation Recommendations

EN

Livingceramics recommends consulting the norms that regulate the placement of ceramic tiles. It is essential, before any installation, to carefully read the UNE 138002 and UNE 12004 standard, and to attend to the specified in order to achieve a correct placement of the ceramic tile. We indicate below, a summary of the most important points to take into account:

ES

Livingceramics recomienda consultar las normas que regulan la colocación de baldosas cerámicas. Es imprescindible, antes de cualquier instalación, leer atentamente las normas UNE 138002 y UNE 12004, y atender a lo especificado en ellas para lograr una correcta colocación de la baldosa cerámica. A continuación, indicamos un resumen de los puntos más importantes a tener en cuenta:

- [01] Conformity of tone and caliber of the material.
Verificar el destonificado y el calibre del material.
- [02] Make sure that the area to clad is clean and dry.
Asegurar que la zona a revestir está limpia y seca.
- [03] Cement-based adhesive should be used for each type of product; porcelain color body or white body.
Utilizar el adhesivo de clase cemento cola según tipología de producto; porcelánico masa coloreada o pasta blanca.
- [04] The area to clad must be uniformly leveled. The use of leveling systems is mandatory for a perfect installation.
El uso de sistemas de nivelación es obligatorio para una perfecta colocación. La zona a revestir debe estar perfectamente nivelada.
- [05] A 2 mm minimum joint is recommended to place the pieces correctly.
Se recomienda una junta mínima de 2 mm para la colocación entre piezas.
- [06] The rectangular formats cannot be placed united to any more than 1/4 of the piece.
Los formatos rectangulares no se pueden colocar trabados a más de 1/4 de la pieza.
- [01] The double bonding technique must always be used.
Se ha de emplear siempre la técnica del doble encolado.
- [02] This material requires the use of C2 class adhesives (bicomponent type S2).
Es recomendable el uso de adhesivos clase C2 altamente flexibles (bicomponentes tipo S2).
- [03] The appearance of air pockets between tile and substrate should be avoided by the systematic knocking of the tile with a rubber trowel. This will avoid tensions and breaks after the material has been set.
Se deberá evitar la aparición de bolsas de aire entre baldosa y sustrato mediante el golpeado sistemático de la cerámica con una llana de goma. Esto evitará tensiones y roturas tras el fraguado del material.
- [04] The use of specific tools for installing ceramic tiles is mandatory. Consult your trusted supplier to receive instructions on the correct handling of these tools and their needs.
Es indispensable utilizar herramientas específicas para el alicatado del gran formato cerámico. Consulte con su proveedor de confianza para recibir instrucciones del correcto manejo de estas herramientas y sus necesidades.



EN

The slab installation requires the use of tools and specific training by the installer. In addition to the above, these are some of the recommendations to take into account in the installation of large tile formats:

ES

La instalación de grandes formatos requiere de herramientas y una formación específica por parte del colocador. A demás de las anteriores, estas son algunas de las recomendaciones a tener en cuenta en la instalación de grandes formatos cerámicos:



Cutting detail with guide on slab.
Detalle de corte con guía sobre plancha.



The tiles' ductile properties make them easy to cut.
Las propiedades especiales de ductile lo hacen más fácil de cortar.



Cleaning & Maintenance

EN

Once placed and grout cleaning equipment is mandatory. Improper cleaning may leave traces of products used in the placement or the protection of the tiles, as cements, resins epoxilicas, grout, waxes or fats. For optimal cleaning after placement for cases of intense and stubborn dirt accumulated over time, and for maintenance, required to use the right products. The following table shows some of the recommendations.

ES.

Una vez colocado y rejuntado el material es obligatoria la limpieza. Una limpieza incorrecta puede dejar restos de productos empleados en la colocación o de la protección de las baldosas, como cementos, resinas epoxilicas, material de rejuntado, ceras o grasas. Para una optima limpieza tras la colocación, para casos de suciedad intensa e incrustada acumulada en el tiempo, y para su mantenimiento, se precisa emplear los productos adecuados. En la tabla siguiente mostramos algunas de las recomendaciones.

The architecture of detail

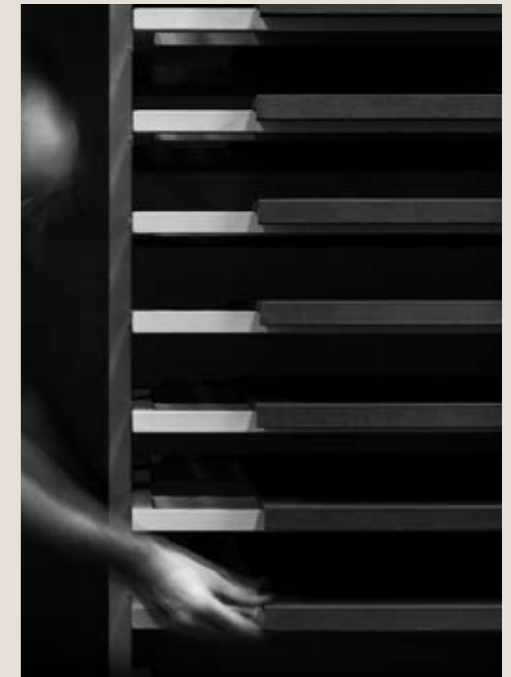

SALES CONDITIONS

[VII]

FILA	FABER	
FILACLEANNER	FLOOR CLEANER	Maintenance in general. <i>Mantenimiento en general.</i>
FILACRIO	EPOXY CLEANER	Waste epoxy, vitrified or resin board. <i>Residuos de junta epoxi, junta vitrificada o junta resinosa.</i>
DETERDEK *	CEMENT REMOVER	Waste concrete placement, limescale, metals stripes, oxide deposits. * DETERDEK not suitable for polished surfaces (Honed finish), For these surfaces, we recommend CEMENT REMOVER 2.0. <i>Residuos de cemento de colocación, residuos calcáreos, rayas metales, depositos de óxido.</i> * DETERDEK no apto para superficies pulidas (acabado Honed), para ellas recomendamos CEMENT REMOVER 2.0
FILASOLV	DEEP DEGREASER	Candle wax, tree resins, tape residue, tar residue. <i>Cera de velas, resina de árbol, residuos de cinta adhesiva, residuos alquitrán.</i>
FILANOPAINT STAR	GRAFFITI REMOVER	Painted graffiti, spray acrylic, alkyd and synthetic nitros. <i>Pintadas de grafitis, spray acrílicos, alquídicos y nitros sintéticos.</i>
FILAPS87	DEEP DEGREASER	Drinks, food, fats, oils, rubber, dyes, marker, acrylic paint drops. <i>Bebidas, comidas, grasas, aceites, goma, tintes, rotulador, gotas de pintura plástica.</i>

EN

The following general terms and conditions govern sales between Lvg ceramic surfaces. S.L. and its clients.

ES.

Las siguientes condiciones generales rigen las compraventas entre LVG ceramic surfaces. S.L. y el cliente.

ORDERS

The obligations of the parties in relation to the delivery of the goods (transfer of risk, costs, insurance, customs formalities, etc.) shall be those arising from the specific conditions agreed upon (INCOTERMS IN FORCE).

The general conditions set out herein, save for any modifications or exceptions expressly agreed upon in writing, shall govern all sales contracts entered into between LVG Ceramic Surfaces, S.L. and the purchaser and, consequently, shall apply both to the contract concluded upon acceptance of the present order and to any future supply contracts for the Company's products placed through successive orders.

Any variations to the general terms and conditions of sale, offers, transactions, credits or discounts agreed upon by our agents or other intermediaries shall not be deemed valid unless expressly accepted in writing by our head office and shall, in any event, be limited exclusively to the contracts to which they expressly refer.

Orders received directly from customers or placed by our representatives on their behalf shall always be subject to our acceptance.

SUPPLY AND RETURNS

Without prejudice to the provisions of the applicable legislation, the purchaser shall examine the goods upon receipt and shall notify in writing any incident, defect or lack of conformity within a reasonable period following such receipt.

Where consumer and user protection regulations are legally applicable, the purchaser shall be entitled to withdraw from the contract within a period of fourteen (14) calendar days from receipt of the product, without stating any reason, in accordance with the terms established by the applicable legislation and without prejudice to the legally established exceptions.

Without prejudice to the foregoing, and as an additional commercial condition, the Returns and Exchanges Policy established by LVG Ceramic Surfaces, S.L. extends the aforementioned statutory minimum period, whereby the customer shall have a total period of thirty (30) calendar days from the date of receipt of the product to request the return or exchange of any non-conforming item, subject to the conditions set out herein.

Returns shall not be accepted in the following cases:

a. Where the packaging or the product is not in perfect condition, has been handled, or shows defects or damage not attributable to LVG Ceramic Surfaces, S.L.

b. Where the goods consist of customised materials manufactured or supplied in accordance with the customer's specifications.

c. Where the goods consist of low-grade ceramic materials.

The customer shall provide the information required by LVG Ceramic Surfaces, S.L. in order to facilitate the return process. Once the return has been accepted by LVG Ceramic Surfaces, S.L., it shall be carried out within fourteen (14) calendar days following the notification of acceptance.

Upon receipt of the returned goods, LVG Ceramic Surfaces, S.L. shall verify that the materials comply with the criteria set forth in this policy and with the information provided in the return request and may, where applicable, proceed with the corresponding refund or product exchange. LVG Ceramic Surfaces, S.L. reserves the right to reject any return that does not comply with the criteria established in this policy.

DELIVERY

All goods supplied by LVG Ceramic Surfaces, S.L. are subject to retention of title. Ownership of the goods shall not pass to the purchaser until full payment has been made.

LVG Ceramic Surfaces, S.L. shall be entitled to offset any amounts owed by the purchaser against any amounts payable to the purchaser.

In the event of non-compliance with the payment terms and/or the return of negotiable instruments, all return costs, as well as any administrative and judicial recovery expenses incurred, including legal fees and court representatives' fees, shall be borne by the purchaser.

In the event of late payment by the purchaser, or if the purchaser's assets are subject to seizure or there is a substantial deterioration in its financial situation, LVG Ceramic Surfaces, S.L. shall be entitled to demand immediate payment of the invoiced amount, withhold pending supplies and condition any further deliveries upon advance payment, without prejudice to any compensation that may be applicable.

Under no circumstances may the goods be resold through online sales platforms unless expressly agreed otherwise. Likewise, unless otherwise specifically agreed, the purchaser is prohibited from exporting the supplied goods or transferring them to third parties for export.

JURISDICTION

The parties expressly submit the contractual relationship between them to the laws of the Kingdom of Spain and, expressly waiving any other jurisdiction that may correspond to them, submit to the Courts and Tribunals of Vila-real (Castellón) for the resolution of any dispute arising in connection with the established commercial relationship.

DATA PROTECTION

In accordance with Regulation (EU) 2016/679 and Organic Law 3/2018 on the Protection of Personal Data and the guarantee of digital rights, the personal data provided by the purchaser shall form part of the data processing systems of LVG Ceramic Surfaces, S.L. for the purpose of managing the contractual relationship, as well as the control and management of sales and the corresponding collections.

The purchaser may exercise the rights of access, rectification, erasure, objection, restriction of processing and data portability by means of a written communication addressed to LVG Ceramic Surfaces, S.L.

NORMATIVA PARA LA CONTRATACIÓN

Las obligaciones de las partes en relación a la entrega de la mercancía (traspaso de responsabilidad, gastos, seguros, trámites aduaneros, etc.) serán las resultantes de las condiciones particulares pactadas (INCOTERMS EN VIGOR).

Las condiciones generales aquí detalladas, salvo posibles modificaciones o excepciones acordadas por escrito, regulan todos los contratos de venta celebrados entre LVG Ceramic Surfaces, S.L. y el comprador, y por consiguiente, tanto el contrato concluido al aceptar el presente pedido, como cualquier futuro contrato de suministro de los productos de nuestra empresa que se soliciten mediante pedidos sucesivos.

Las variaciones de las condiciones generales de venta, las ofertas, las transacciones, los abonos o los descuentos acordados por nuestros agentes u otros intermediarios no se considerarán válidos si nuestra sede no los ha aceptado por escrito, limitándose, en cualquier caso, a los contratos a los que se referan.

Los pedidos recibidos directamente de los clientes o realizados por nuestros representantes en nombre de ellos estarán siempre sujetos a nuestra aceptación.

SUMINISTRO Y DEVOLUCIÓN

Sin perjuicio de lo dispuesto en la normativa aplicable, el comprador deberá examinar la mercancía en el momento de su recepción y comunicar por escrito cualquier incidencia o falta de conformidad en un plazo razonable desde dicha recepción.

Cuando resulte legalmente aplicable la normativa de protección de consumidores y usuarios, el comprador dispondrá de un plazo de 14 días naturales desde la recepción del producto para desistir del contrato, sin necesidad de indicar el motivo, en los términos previstos en la normativa vigente y sin perjuicio de las excepciones legalmente establecidas.

Sin perjuicio de lo anterior, y como condición comercial adicional, la Política de Cambios y Devoluciones establecida por LVG Ceramic Surfaces, S.L. amplía dicho plazo mínimo legal, por lo que el cliente dispondrá de un plazo total de 30 días naturales desde la fecha de recepción del producto para solicitar la devolución o el cambio de cualquier artículo no conforme, de conformidad con los condicionantes aquí indicados.

No se aceptarán devoluciones en los siguientes supuestos:

a. Cuando el embalaje o el producto no se encuentren en perfecto estado, hayan sido manipulados o presenten defectos o roturas no imputables a LVG Ceramic Surfaces, S.L.

b. Cuando se trate de material personalizado fabricado o suministrado conforme a las especificaciones del cliente.

c. Cuando se trate de materiales cerámicos de clases bajas.

El cliente deberá aportar la información requerida por LVG Ceramic Surfaces, S.L. para facilitar el proceso de devolución. Tras la confirmación por parte de LVG Ceramic Surfaces, S.L. de la aceptación de la devolución, esta se realizará dentro de los 14 días naturales siguientes a la notificación.

Una vez LVG Ceramic Surfaces, S.L. reciba la mercancía devuelta, se comprobará que el material cumple con los criterios establecidos en esta política y con la información aportada en la solicitud de devolución, pudiendo proceder, en su caso, al abono correspondiente o al cambio del producto.

LVG Ceramic Surfaces, S.L. se reserva el derecho de rechazar devoluciones que no cumplan con los criterios establecidos en la presente política.

ENTREGA

Las mercancías entregadas por LVG Ceramic Surfaces, S.L. están sujetas a reserva de dominio. La propiedad de la mercancía únicamente pasará al comprador en el momento en que esté completamente pagada.

LVG Ceramic Surfaces, S.L. tendrá derecho a compensar cualquier suma que le adeude el comprador contra cualquier suma que resulte pagadera al comprador.

En caso de incumplimiento de las condiciones de pago y/o devolución de los efectos negociados, serán de cuenta del comprador los gastos de devolución, así como los gastos de administración y reclamación judicial que se originen en su caso, incluidos los honorarios de letrados y procuradores.

En caso de mora en el pago de la mercancía por el comprador, así como si sufriera embargo en sus bienes o se produjera un empeoramiento sustancial de su situación patrimonial, LVG Ceramic Surfaces, S.L. estará facultada para reclamar el pago inmediato del importe facturado, retener los suministros pendientes y condicionar nuevas entregas al pago por adelantado de las mismas, sin perjuicio de la indemnización que, en su caso, pudiera corresponder.

En ningún caso la mercancía podrá ser objeto de reventa mediante el uso de páginas web de venta online, salvo acuerdo expreso en contrario. Igualmente, y salvo pacto específico, se prohíbe al comprador exportar los materiales suministrados o cederlos a terceros para su exportación.

TRIBUNAL COMPETENTE

Las partes someten las relaciones resultantes entre las mismas a lo dispuesto en la legislación del Reino de España y, con renuncia expresa al fuero que pudiera corresponderles, se someten a los Juzgados y Tribunales de Vila-real (Castellón) para resolver cualquier controversia que surja en relación con la relación comercial establecida.

PROTECCIÓN DE DATOS

De conformidad con el Reglamento (UE) 2016/679 y la Ley Orgánica 3/2018, de Protección de Datos Personales y garantía de los derechos digitales, los datos personales facilitados por el comprador formarán parte de los sistemas de tratamiento de LVG Ceramic Surfaces, S.L., con la finalidad de gestionar la relación contractual, el control y la gestión de las ventas y sus correspondientes cobros.

El comprador podrá ejercitar los derechos de acceso, rectificación, supresión, oposición, limitación del tratamiento y portabilidad mediante comunicación escrita dirigida a LVG Ceramic Surfaces, S.L.

HEADQUARTERS AND WAREHOUSE
OFICINAS Y LOGÍSTICA

Ctra. Vila-real – Onda CV 20 KM 2.5
12540, Vila-real, Castellón, Spain

Production Center | Centro de Producción
Ctra. Onda – Ribesalbes CV 191 KM 3
12200, Onda, Castellón, Spain

SHOWROOM VILA-REAL

Ctra. Vila-real – Onda CV 20 KM 2.5
12540, Vila-real, Castellón, Spain
Tel. +34 964 914 181

SHOWROOM BARCELONA

Avenida Diagonal 499
08029, Les Corts, Barcelona, Spain
Tel. +34 936 118 308

SHOWROOM MADRID

Calle Lagasca, 16. Bajo, dcha.
Salamanca, 28001 Madrid
Tel. +34 912 964 256

info@livingceramics.com
Tel. +34 964 914 181

www.livingceramics.com

Livingceramics

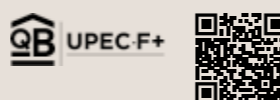

LEGAL INFORMATION

LVG Ceramic Surfaces. S.L. reserves the right to make changes and modifications deemed necessary due to process modifications or errors in the catalogue. Because of the printing process, the colors shown in this catalogue are approximate, not exact. The information in this catalogue is fully protected by copyright. Total or partial reproduction of text, illustrations, images and graphical representations is forbidden without the express permission of Livingceramics.

SME INNOVATIVE

The Spanish Ministry for Science, Innovation & Universities rewards Livingceramics efforts in the fields of R&D and innovation. This mention is the outcome of the incorporation of state-of-the-art technology to our production plant in order to produce large-format tiles conspicuous for their unique finishes.

INFORMACIÓN LEGAL

LVG Ceramic Surfaces. S.L. se reserva el derecho de hacer variaciones y modificaciones que considere oportunas por modificaciones de procesos o errores en el catálogo. A causa de los procesos de impresión, los colores que aparecen en este catálogo deben considerarse aproximados, no exactos. La información de este catálogo está protegida en su totalidad por copyright. Está prohibida la reproducción total o parcial de los textos, ilustraciones, imágenes y representaciones gráficas sin la autorización expresa de Livingceramics.

PYME INNOVADORA

El Ministerio de Ciencia, Innovación y Universidades reconoce a Livingceramics la inversión en investigación y Desarrollo de productos diferenciadores en la industria cerámica actual. Se trata de un reconocimiento estatal que verifica la inversión realizada por la empresa en su proceso de producción y búsqueda continua. Galardona así la innovación y el esfuerzo realizado por Livingceramics a la hora de invertir en I+D+i.

